



# DRAFT ENVIRONMENTAL MAINTENANCE MANAGEMENT PLAN

for  
**GAMKABERG NATURE  
RESERVE ROAD  
MAINTENANCE & REPAIRS**

In terms of the  
National Environmental Management Act (Act  
No. 107 of 1998, as amended) & 2014  
Environmental Impact Regulations

Prepared for Applicant: CapeNature

Date: 20 February 2026

Author of Report: Louise-Mari van Zyl

Author Email: [louise@cape-eaprac.co.za](mailto:louise@cape-eaprac.co.za)

Report Reference: WES914b/03

Department Reference: 14/12/16/3/1/1/418/MP1

**Cape EAPrac**

Cape Environmental Assessment Practitioners

Tel: +27 44 874 0365 PO Box 2070, George 6530  
Fax: +27 44 874 0432 17 Progress Street, George

[www.cape-eaprac.co.za](http://www.cape-eaprac.co.za)



DRAFT ENVIRONMENTAL MANAGEMENT MAINTENANCE PLAN

---

**APPOINTED ENVIRONMENTAL ASSESSMENT PRACTITIONER:*****Cape EAPrac Environmental Assessment Practitioners*****PO Box 2070****George****6530****Tel: 044-874 0365****Fax: 044-874 0432**

Report written & compiled by: Louise-Mari van Zyl (Masters' Degree), who has 23 years' experience as an environmental practitioner.

Registrations: **Louise-Mari van Zyl** (Registered Environmental Assessment Practitioner with the Interim Certification Board for Environmental Assessment Practitioners of South Africa, EAPSA).

**PURPOSE OF THIS REPORT:**

Stakeholder Review and Comment

**APPLICANT:**

CapeNature

**CAPE EAPRAC REFERENCE NO:**

WES914b/03

**DEPARTMENT REFERENCE:**

14/12/16/3/1/1/418/MP1

**SUBMISSION DATE**

26 February 2026

# DRAFT ENVIRONMENTAL MAINTENANCE MANAGEMENT PLAN

in terms of the

National Environmental Management Act, 1998 (Act No. 107 of 1998), as amended &  
Environmental Impact Regulations 2014

GAMKABERG NATURE RESERVE ROAD MAINTENANCE & REPAIRS

**Western Cape Province**

Submitted for:

## Stakeholder Review & Comment

- This report is the property of the Author/Company, who may publish it, in whole, provided that:
- Written approval is obtained from the Author and that *Cape EAPrac* is acknowledged in the publication;
- *Cape EAPrac* is indemnified against any claim for damages that may result from any publication of specifications, recommendations or statements that is not administered or controlled by *Cape EAPrac*;
- The contents of this report, including specialist/consultant reports, may not be used for purposes of sale or publicity or advertisement without the prior written approval of *Cape EAPrac*;
- *Cape EAPrac* accepts no responsibility by the Applicant/Client for failure to follow or comply with the recommended programme, specifications or recommendations contained in this report;
- *Cape EAPrac* accepts no responsibility for deviation or non-compliance of any specifications or recommendations made by specialists or consultants whose input/reports are used to inform this report; and
- All figures, plates and diagrams are copyrighted and may not be reproduced by any means, in any form, in part or whole without prior written approved from *Cape EAPrac*.

**Report Issued by:**

***Cape Environmental Assessment Practitioners***

Tel: 044 874 0365

Fax: 044 874 0432

Web: [www.cape-eaprac.co.za](http://www.cape-eaprac.co.za)

PO Box 2070

17 Progress Street

George 6530



## 1 EXECUTIVE SUMMARY

Gamkaberg Nature Provincial Reserve and World Heritage Site (ANR&WHS) is located in the Western Cape province within the western Klein Karoo. The Gamkaberg Nature Reserve which is also a World Heritage Site, was established in 1974 to conserve a small, remnant herd of endangered Cape mountain zebra.

In compliance with the National Environmental Management: Protected Areas Act (NEMPAA Act 57 of 2003), the Reserve is operated as a protected area. In accordance CapeNature's mandate for this Reserve, the remote areas of the Reserve must be visited and inspected for alien clearing, species surveys, fence management, as well as fire break management requirements. To implement these important reserve management actions, **vehicular access** is critical to transport rangers throughout and across the Reserve to remote boundaries and locations, which may also include tourist accommodation facilities and hiking routes.

Several of the **existing internal access roads and management tracks have been damaged and/or are severely eroded**, especially at stream crossings, because of stormwater and/or flood damage. Although located in a semi-arid region, the location of the Reserve in very mountainous terrain, resulting in runoff causing severe erosion and damage along roads/tracks, as well as damage to physical structures in more prominent watercourses.

The damaged roads and eroded tracks, prohibit safe access and in some instances, result in temporary closure of important management routes to some parts of the Reserve, where it is not possible to travel even with appropriate 4x4 vehicles, or reach tourist accommodation units.

**Repair and maintenance of the damaged roads and tracks is essential.** Not only do lack of, or limited access to remote species survey areas and boundary fences restrict CapeNature's ability to implement their mandate within the Reserve, it compromises their ability to adhere to their management protocols in an effective manner. Furthermore, the Reserve relies on eco-tourism through visiting tourists and research groups who's access to the Reserve become increasingly restricted because of the road damage. The resulting loss of income when CapeNature cannot offer all its accommodation opportunities and eco-tourist activities such as overnight hiking trail events, have a direct financial implication for Reserve operations.

The National Environmental Management Act (NEMA) makes allowance for the **repair and maintenance of existing lawful structures and infrastructure**, such as roads and water crossings, under guidance of an adopted Environmental Maintenance Management Plan (EMMP) on condition that structures/infrastructure is repaired/maintained on a **like-for-like basis where capacity and/or footprint is not increased** and the **structure/infrastructure remains in the same position/location**.

This EMMP deals with the repair and maintenance of existing roads/tracks within the Reserve, with its associated structures and infrastructure, within the scope of this definition.

Importantly this EMMP takes note of the *Guidelines for the Development of a Management Plan for a Protected Area* in terms of the NEM:PAA and the *Guidelines for Development of an Environmental Management Plans* in terms of the NEMA.

## 2 PURPOSE OF THIS REPORT

Considering the landscape, topography and ecological sensitivity of the Reserve and its receiving environment, which is characterised by minor and major (mostly) non-perennial watercourses, catchment management area functions, and threatened vegetation types, maintenance of the internal roads/tracks must be conducted in a controlled, lawful, and environmentally responsible manner.

The purpose of this EMMP is to provide a structured, legally compliant framework that enables CapeNature to conduct routine and emergency maintenance activities within the existing disturbed road/track footprints, without triggering listed activities that may require additional *prior* Environmental Authorisation (EA).

This report outlines the maintenance activities required, ensures that all interventions remain like-for-like, and prescribes the mitigation and management measures necessary to safeguard ecological and hydrological processes during periods of maintenance/repair.

This EMMP has been prepared in accordance with the National Environmental Management Act, 1998 (Act No. 107 of 1998; NEMA) and the Environmental Impact Assessment (EIA) Regulations, 2014 (as amended), which allow for the adoption of an EMMP to regulate maintenance activities in sensitive environments, including Protected Areas declared under the National Environmental Management: Protected Areas Act, 2003 (Act No. 57 of 2003; NEM:PAA).

Adoption of this MMP by the National Department of Forestry, Fisheries and the Environment (DFFE), as the competent authority, will enable the necessary repair and maintenance works to be undertaken in a regulated manner.

Once adopted, this EMMP must be adhered to by CapeNature and any party/employees responsible for conducting similar maintenance or repair works. The EMMP must be reviewed on a five (5) year cycle and the DFFE must be informed if there is any need for amendments or updates to this EMMP.

## 3 ORDER OF REPORT

The EMMP comprises of several important sections, namely:

**Section 1** outlines the **project background, need, and desirability** of the repairs and maintenance.

**Section 2** provides an **environmental baseline**, including desktop vegetation, aquatic systems, biodiversity, heritage resources, and sensitive habitats.

**Section 3** states the **legislative and policy framework** applicable to maintenance within Protected Areas.

**Section 4** provides for **sensitivities, impact identification and assessment**, along with impact management outcomes and corresponding mitigation measures, confirming that no long-term negative impacts are expected with the correct and continued implementation of this EMMP.

DRAFT ENVIRONMENTAL MANAGEMENT MAINTENANCE PLAN

---

**Section 5** deals with monitoring and compliance requirements;

**Section 6** reports on method statements aligned with the Western Cape Government (WCG) and Department of Infrastructure Maintenance Methods Manual (2021);

Whilst **Section 7** details the Public Participation Process to support transparency and compliance with the EIA Regulations, 2014 (as amended).

## 4 PUBLIC PARTICIPATION

---

This EMMP is submitted as a draft report for review and comment by key stakeholders, including mandated Authorities, Organs of State and members of the public for a period no less than 30-days extending from **Friday, 27 February – Monday, 30 March 2026**.

- Newspaper advert has been placed in *Oudtshoorn Courant*, as well as the *Prins Albert Friends Newspaper*, calling for I&APs to participate and comment on the document;
- Site Notices have been put up at the Gamkaberg Nature Reserve office, and the Reserve's main entrance gate;
- Electronic copy of the document is available and can be downloaded from [www.cape-eaprac.co.za](http://www.cape-eaprac.co.za) (listed under 'Active Projects') and a hard copy is available at the Gamkaberg Nature Reserve office for viewing.

Following the outcome of the stakeholder engagement process, this draft EMMP will be updated to reflect submissions received and all submissions will be considered and responded to in order to capture potential outstanding information / oversights or corrections that may be necessary.

All submission must be made, in writing or orally to the addresses below, and must reach us no later than 30 March 2026 in order for such submissions to be considered:

Cape Environmental Assessment Practitioners (Pty) Ltd

c/o Louise-Mari van Zyl (Registered EAP, Reg Nu 2019/1444)

Email: [louise@cape-eaprac.co.za](mailto:louise@cape-eaprac.co.za)

Tel: 044-8740365 (verbal communication / comments will be captured)

## 5 CONCLUSION

---

The Environmental Regulations define 'maintenance' as '*.....actions performed to keep a structure, or system, functioning, or in service on the same location, capacity and footprint*' with a 'maintenance management plan' described as the '*.....plan for maintenance purposes defined, or adopted by the Competent Authority*'.

The formal Application for Adoption of the EMMP, has been made to the DFFE (Competent Authority) and the file reference number and case officer awarded prior to this draft report being circulated for comment. A copy of the pre-application meeting minutes is included with this report for transparency.

---

DRAFT ENVIRONMENTAL MANAGEMENT MAINTENANCE PLAN

---

It is submitted that the proposed like-for-like maintenance work can be contained and implemented without the need for further environmental approvals once this EMMP has been adopted.

The potential impacts resulting from repairs and maintenance proposed by the appointed project Engineers, are deemed acceptable and will not result in long-term environmental degradation or cause undue harm to the receiving environment.

---

## CONTENTS

<b>1</b>	<b>EXECUTIVE SUMMARY .....</b>	<b>III</b>
<b>2</b>	<b>PURPOSE OF THIS REPORT .....</b>	<b>IV</b>
<b>3</b>	<b>ORDER OF REPORT .....</b>	<b>IV</b>
<b>4</b>	<b>PUBLIC PARTICIPATION.....</b>	<b>V</b>
<b>5</b>	<b>CONCLUSION .....</b>	<b>V</b>
<b>1</b>	<b>INTRODUCTION .....</b>	<b>1</b>
<b>2</b>	<b>SPECIFIC INTERVENTIONS AND WORK AREAS.....</b>	<b>2</b>
<b>3</b>	<b>NEED &amp; DESIRABILITY.....</b>	<b>6</b>
<b>4</b>	<b>LEGISLATION OVERVIEW.....</b>	<b>7</b>
4.1	NATIONAL ENVIRONMENTAL MANAGEMENT ACT, 1998 (NEMA) NEMA P .....	7
4.1.1	<b>Section 2: Environmental Management Principles .....</b>	<b>7</b>
4.1.2	<b>Section 28: Duty of Care Section 28.....</b>	<b>8</b>
4.1.3	<b>Section 30: Emergency Incidents Section 30 of NEMA.....</b>	<b>9</b>
4.1.4	<b>Listed Activities Relevant to the Proposed Works .....</b>	<b>9</b>
8.3	NATIONAL ENVIRONMENTAL MANAGEMENT: PROTECTED AREAS ACT, 2003 (NEM: PAA) .	11
8.4	NATIONAL WATER ACT, 1998 (ACT NO. 36 OF 1998) .....	12
<b>5</b>	<b>ENVIRONMENTAL BASELINE FOR THE WORK AREAS.....</b>	<b>12</b>
<b>6</b>	<b>ENGINEERING INTERVENTIONS.....</b>	<b>17</b>
6.1	TYPICAL LOW-LEVEL CROSSING DESIGN: .....	19
6.2	TYPICAL DRIFT DESIGN:.....	20
6.3	TYPICAL GABION / CONCRETE REINFORCED STABILISING WALL DESIGN:.....	21
<b>7</b>	<b>IMPACT ASSESSMENT AND MANAGEMENT RECOMMENDATIONS .....</b>	<b>21</b>
7.1	POTENTIAL RISKS AND IMPACTS.....	22
7.1.1	<b>Animal Species – High sensitivity (all sections).....</b>	<b>22</b>
7.1.2	<b>Aquatic Biodiversity – Very High sensitivity .....</b>	<b>23</b>
7.1.3	<b>Palaeontology – Very High.....</b>	<b>25</b>
7.1.4	<b>Plant species – High   Terrestrial Biodiversity – Very High .....</b>	<b>26</b>
7.2	IMPACT MANAGEMENT ACTIONS AND OUTCOMES .....	28
7.3	GENERAL MANAGEMENT CONDITIONS .....	1
<b>8</b>	<b>MONITORING, REPORTING &amp; INDICENTS .....</b>	<b>3</b>
8.1	INCIDENTS & REPORTING .....	3

---

 DRAFT ENVIRONMENTAL MANAGEMENT MAINTENANCE PLAN
 

---

8.2	ROLE AND RESPONSIBILITY OF THE ECO .....	5
8.3	FREQUENCY OF INSPECTIONS .....	6
8.4	REPORTING .....	6
<b>9</b>	<b>STAKEHOLDER ENGAGEMENT .....</b>	<b>8</b>
<b>10</b>	<b>REFERENCES .....</b>	<b>9</b>

Table 1: List of affected areas within the Gamkaberg Nature Reserve (Source: V3 Consulting Engineers).....4

Table 2: Short summary of repair and maintenance work along the five sections of road/track in Gamkaberg Nature Reserve.....4

Table 3: Screening Tool sensitivities – Gamkaberg Nature Reserve.....22

## DRAFT ENVIRONMENTAL MANAGEMENT MAINTENANCE PLAN

Appendix 4 of Regulation 326 of the 2014 EIA Regulations (as amended) contains the required contents of an Environmental Management Programme (EMMP). The checklist below serves as a summary of how these requirements were incorporated and adopted for the purpose of this EMMP:

Requirement	Description
(1) A EMMP must comply with section 24N of the Act and include -	Noted
(a) Details of (i) The EAP who prepared the EMMP; and (ii) The expertise of the EAP to prepare an EMMP, including a curriculum vitae.	Louise-Mari van Zyl EAPASA registered: 2019/1444 Practicing as an EAP since 2002
(b) A detailed description of the aspects of the activity that are covered by the EMMP as identified by the project description.	Main Report
(c) A map at an appropriate scale which superimposes the proposed activity, its associated structures, and infrastructure on the environmental sensitivities of the preferred site, indicating any areas that should be avoided, including buffers	Main Report & Appendices
(d) A description of the impact management outcomes, including management statements, identifying the impacts and risks that need to be avoided, managed and mitigated as identified through the environmental impact assessment process for all the phases of the development including – (i) Planning and design; (ii) Pre-construction activities; (iii) Construction activities; (iv) Rehabilitation of the environment after construction and where applicable post closure; and	Main Report

## DRAFT ENVIRONMENTAL MANAGEMENT MAINTENANCE PLAN

Requirement	Description
(v) Where relevant, operation activities.	
<p>(e) A description of the proposed impact management actions, identifying the manner in which the impact management outcomes contemplated above will be achieved and must, where applicable include actions to –</p> <p>(i) Avoid, modify, remedy control or stop any action, activity or process which causes pollution or environmental degradation;</p> <p>(ii) Comply with any prescribed environmental management standards or practices;</p> <p>(iii) Comply with any applicable provisions of the Act regarding closure, where applicable; and</p> <p>(iv) Comply with any provisions of the Act regarding financial provisions for rehabilitation, where applicable.</p>	Main Report
(f) The method of monitoring the implantation of the impact management actions contemplated above.	Main Report
(g) The frequency of monitoring the implementation of the impact management actions contemplated above.	Main Report
(h) An indication of the persons who will be responsible for the implementation of the impact management actions.	Main Report
(i) The time periods within which the impact management actions must be implemented.	Main Report
(j) The mechanism for monitoring compliance with the impact management actions.	Main Report

## DRAFT ENVIRONMENTAL MANAGEMENT MAINTENANCE PLAN

Requirement	Description
(k) A program for reporting on compliance, taking into account the requirements as prescribed in the Regulations.	Main Report
(l) An environmental awareness plan describing the manner in which –  (i) The applicant intends to inform his or her employees of any environmental risk which may result from their work; and  (ii) Risks must be dealt with in order to avoid pollution or the degradation of the environment.	Main Report
(m) Any specific information that may be required by the competent authority.	Appendices

## 1 INTRODUCTION

Cape Environmental Assessment Practitioners (Pty) Ltd, hereafter referred to as *Cape EAPrac*, has been appointed to act as independent environmental assessment practitioner (EAP) to facilitate the process of adoption of an environmental maintenance management plan (EMMP) for the Gamkaberg Provincial Nature Reserve and World Heritage Site located approximately 25km South-West of Oudtshoorn and 23km South-West of Calitzdorp, in the Garden Route District Municipal region of the Western Cape Province (33°40'15.53"S | 21°53'21.25"E).

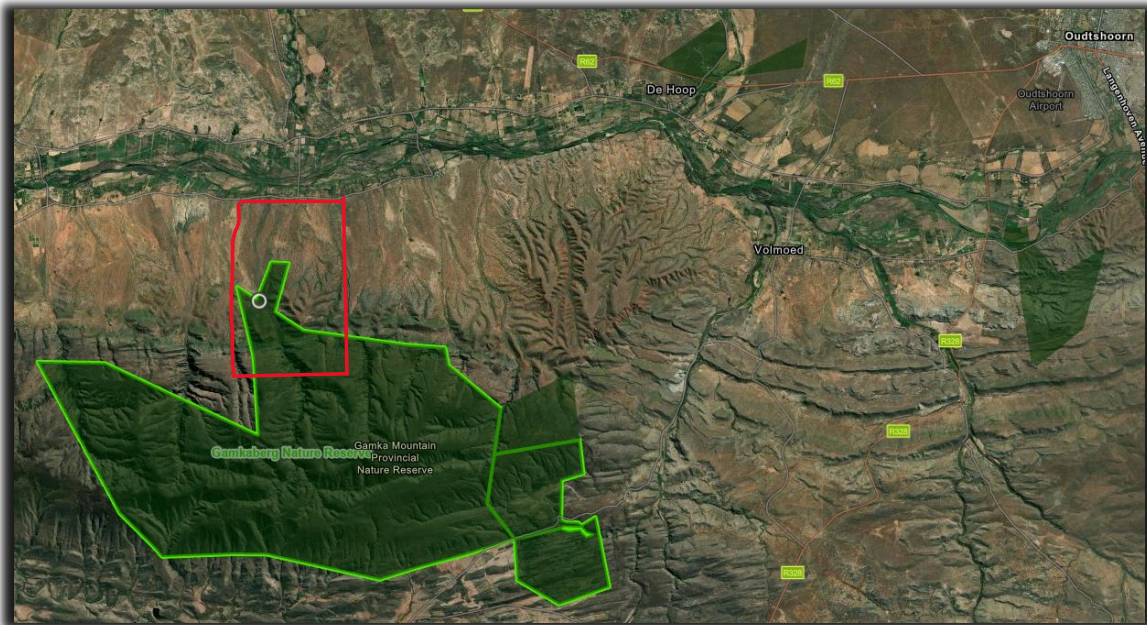

Figure 1: Location of Gamkaberg Nature Reserve in the Garden Route District Municipal region in the Klein Karoo (Source: CapeFarmMapper).

The far Northern portion of the Gamkaberg Nature Reserve were the road repair and maintenance is required as presented in this EMMP. Several non-perennial stream crossings are visible along the length of the route of the (a) Servitude main access, (b) Road A to the accommodation and (c) Road B to the staff accommodation.



## DRAFT ENVIRONMENTAL MANAGEMENT MAINTENANCE PLAN

This EMMP draws from the *Condition Assessment – Stormwater Damage* report compiled by V3 Consulting Engineers<sup>1</sup>, dated 30 July 2025 (Ref: 11755010) that was specifically compiled to evaluate the state of damaged roads/tracks and provide technical advice by qualified engineers, on how best to repair the damaged sections of roads/tracks. The majority of damage stems from high rainfall events during 2024. Furthermore, the EAP conducted a site inspection during mid-September 2025, accompanied by the Reserve Manager, to ground-truth environmental site conditions.

The Reserve is large and covers mountainous terrain with internal roads/tracks crossing numerous tributaries and larger watercourses. Albeit that these waterways have little to no runoff for the most part of a year, when sufficient rain does fall, the runoff erodes water crossings and road surfaces. In addition, the rocky terrain results in runoff carrying great volumes of sand/rocks with it which exacerbates damage to existing structures/infrastructure and cause blockages of culverts/stormwater pipes, as well as road surfaces.

The Reserve falls within the Albany Thicket biome with the ecosystem threat status of Least Threatened designated to the Oudtshoorn Karroid Thicket vegetation type found throughout the Reserve.

To address the damage and to enable lawful maintenance in future, the opportunity for 'like-for-like' repairs and maintenance is considered through this EMMP.

**Maintenance:** *Actions performed to keep a structure, or system functioning or in service, on the same location, capacity and footprint.*

Environmental Regulations. 2017

## 2 SPECIFIC INTERVENTIONS AND WORK AREAS

Within the greater Reserve, there are three (3) road/track sections where repair and maintenance work is required, noting that ongoing maintenance of other roads that do not trigger the need for an EMMP to be adopted, falls outside the scope of this EMMP.

Likewise, any work involving 'new' structures and/or infrastructure that may require additional *prior* Environmental Authorisation to the National Environmental Management Act (NEMA) and/or National Water Act (NWA) are also not included under this EMMP and will be subject to future, independent Basic Assessment application processes.

<sup>1</sup> Appointed by Western Cape Government Department of Infrastructure who funds the maintenance work.

**Watercourse:** A river or spring, a natural channel in which water flows regularly or intermittently, a wetland, pan, lake or dam into which, or from which, water flows and any collection of water which the Minister my, declare to be a watercourse as defined in the National Water Act.

National Water Act, 1998

Damage observed by V3 and the appointed EAP include erosion along roads caused by either sheet flow or where water overtop the road/tracks due to existing culverts/pipes being blocked, damage to culverts/stormwater pipes, drifts, gabions and reno mattresses as a result of flooding resulting in unwanted erosion of the bed/banks of tributaries/watercourses, failure of existing low-level crossings due to flood damage and the deposit of silt,

debris, grit, rocks and sand both upstream and downstream of existing low level watercourse crossings that affects hydrology of the system and causes erosion. For ease of reference, the identified roads within the Reserve that's applicable to this EMMP are depicted in the following Figure whereas Table 1 explains each of the different road/track sections in terms of their respective uses.

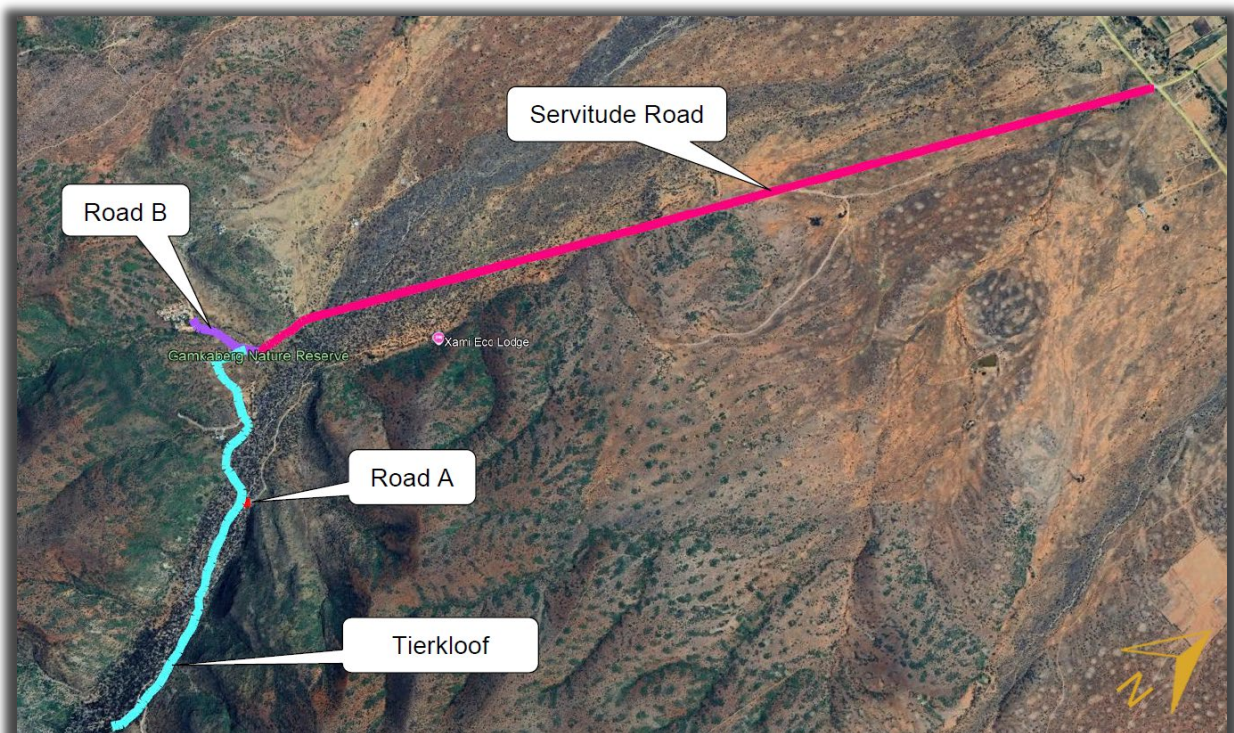

Figure 2: Primary three road sections subject to maintenance and repair work (Source: V3 Consulting Engineers, July 2025).

## DRAFT ENVIRONMENTAL MANAGEMENT MAINTENANCE PLAN

Table 1: List of affected areas within the Gamkaberg Nature Reserve (Source: V3 Consulting Engineers).

ROAD / TRACK SECTION	USAGE	DESCRIPTION
Servitude Road (Portion 44 Farm 80, Portion 45 Farm 80, Portion 43 Farm 80, Portion 42 Farm 80)	Primary access to the Reserve	Road is a wide formalised gravel road. This road section is approximately 3.8km in length.
Road A (Portion 14 Farm 154)	Primary access to tourist accommodation	Narrow gravel track with several stream crossings. This track is approximately 1.8km in length.
Road B (Portion 14 Farm 154)	Primary access to the staff village/employees residences	Narrow gravel track with stream crossings. This track is approximately 0.3km in length.

Below table provides more specific details for repairs and maintenance, with the following as a more general summary:

- Fix erosion gulleys along road verges and adjacent areas that formed as a result of failing/blocked/damaged infrastructure;
- Repair existing damaged culverts, drifts and in-stream low level crossing structures;
- Repair supporting in-stream supporting structures/infrastructure by replacing gabions/reno mattresses/drainage structures (including headwalls, wing walls, apron slabs / inlet and outlet structures);
- Removal of silt / sand / rock / grit deposits / debris obstructing or compromising mobility of the roads/tracks and stormwater flow structures;
- Replace in situ rockfill with wire baskets containing the rockfill (reno mattresses) or replace rock gabions/reno mattress crossings with cement drifts, at water crossings to reduce maintenance at damaged to crossings;
- Trimming and removal of vegetation directly associated with maintenance work;
- Removal of vegetation encroaching onto the road surface and regrowth on the road surface.

Notably all of the work must be conducted in a like-for-like manner, no increasing capacity or footprint, whilst reducing long-term risk of repeated damage to the road/tracks i.e. ensuring a more sustainable structure/infrastructure replacement.

Table 2: Short summary of repair and maintenance work along the five sections of road/track in Gamkaberg Nature Reserve.

SPECIFIC WORK AREA	INTERVENTIONS
Servitude Road	3.8km This graded gravel track consists of a compacted soil surface. Soil erosion is evident with the road showing clear signs of water-induced degradation with multiple gulleys formed along the road length. Failing stormwater infrastructure along this road along non-perennial tributaries and streams result in overtopping with high-flow transporting boulders, cobbles and sediment onto

## DRAFT ENVIRONMENTAL MANAGEMENT MAINTENANCE PLAN

	<p>and over the road surface. Road stability, safety and erosion control is compromised as a result of the inadequate stormwater management infrastructure.</p> <p>As the main access to the Reserve, ensuring that this road remains functional and fit-for-purpose at all times is critical since it is the only route by which employees and visitors alike can get into, or out of the Reserve.</p>
Road A	<p>1.8km</p> <p>This track is exposed to poor stormwater management affecting the road's stability and structural integrity. Existing gabions and reno mattresses installed at non-perennial crossings show evidence of eroded mesh and damage to the structures where it has washed away/broken needing re-instatement. Low level crossings and culverts/pipes often get blocked with boulders, cobbles and sediment during high flow events, resulting in the road becoming inaccessible and/or high-energy water flow creating erosion gulleys up and downstream of a crossing due to failing stormwater management infrastructure.</p> <p>This track is the only vehicle access route to the existing tourist accommodation in the lower lying portion of the Reserve. Ensuring that this track remains accessible is essential to allow staff to travel to more remote areas of the Reserve, as well as servicing the tourist accommodation units and for tourists/visitors needing to traverse the Reserve and get to and from their accommodation.</p>
Road B	<p>0.3km</p> <p>As the only vehicular access to staff accommodation, damage to the track results in staff not being able to get to the Reserve Office, or fulfill their duties on the Reserve, or get to and from town for daily tasks such as children needing to get to school.</p> <p>Due to the low lying terrain water accumulates across the entire stretch of the track making pedestrian access unsafe, whilst vehicle access impossible for extended periods of time.</p>

Notably the repairs and maintenance described above, can be undertaken as regular/scheduled/ad hoc or emergency maintenance on condition that CapeNature adheres to the adopted EMMP.

No new structures or infrastructure beyond the scope/footprint/location of the existing roads and tracks may be installed / constructed. New structures/infrastructure beyond the scope of this EMMP will require separate Environmental Authorisation by means of a Basic Assessment process.

### 3 NEED & DESIRABILITY

Without repairs and maintenance of the identified tracks/roads within the Reserve, CapeNature is unable to service their fences along boundaries, they are not be able to access important species monitoring sites that are in remote locations across the Reserve, they are not be able to provide continued vehicle access for tourists/hikers to some of the more remote accommodation units (or ensure safe evacuation of such accommodation facilities in the event of a fire/flooding) and staff cannot access/perform their duties.

Similarly CapeNature are not able to perform effective fire management within the Reserve (cannot access areas where fire breaks need to be maintained) or implement alien vegetation clearing (cannot access areas with vehicles necessary take clearing teams and equipment for cutting off invasive species). If CapeNature is unable to perform these duties, there is an increased risk of wildfires, animals escaping via broken fences, reduced ecological importance, as well as lack of income from eco-tourism opportunities within the protected area.

The existing roads/tracks form the basis / backbone for access, maintenance, research and tourism and therefore must be maintained and kept in a safe and working condition.

The following criteria provides a common baseline to determine whether an EMMP is the most suitable 'environmental tool' to consider and ultimately allows for the implementation of repair/maintenance work:

<b>As an EMMP the most appropriate decision-making tool:</b>	<b>Answer</b>	
Is there evidence of the presence of existing structures / infrastructure that has been damaged/eroded that can be repaired in a like-for-like manner to improve sustainability of the structure / infrastructure?	YES	NO
Will proposed repair / maintenance increase the footprint or capacity of the observed existing infrastructure / structures to prevent / reduce maintenance?	YES	NO
Is there evidence of existing structures / infrastructure not able to function as intended, as a result of overgrown vegetation / erosion / silt build-up?	YES	NO
Can repair and maintenance work be undertaken without 'triggering' any Listed Activities into the NEMA and NWA?	YES	NO
Will repair and maintenance actions improve and/or extend the lifespan of the existing structure / infrastructure?	YES	NO

V3 Consulting Engineers in their Status Assessment report, provides specific details for the type of repair and maintenance work applicable to this EMMP. Their proposals fall within the above-mentioned categories except for where new structures/infrastructure must be installed in which case CapeNature must apply for prior Environmental Authorisation (EA) since new structures/infrastructure falls outside the scope of this EMMP.

By adopting this EMMP, the Competent Authority will facilitate both proactive and reactive maintenance interventions that safeguard ecological functioning, while ensuring the continued safety and operability of roads/tracks within the nature reserve.

## 4 LEGISLATION OVERVIEW

The proposed maintenance and repairs on the Gamkaberg Nature Reserve falls within a protected area which significantly elevates the need for compliance and monitoring of repair work and maintenance in ecologically sensitive areas.

The Gamkaberg Nature Reserve forms part of the greater 80 000ha Gamkaberg Conservation Area, which is made up of various categories of protected areas, including privately owned stewardship nature reserves. In 2015, Gamkaberg Nature Reserve was included as one of the protected areas making up the Cape Floral Kingdom Protected Areas World Heritage Site, declared South Africa's 6th World Heritage Site in 2004.

This MMP is prepared in terms of NEMA and the EIA Regulations, 2014 (as amended), and is intended for adoption by DFFE as the Competent Authority. The legal framework governing the preparation, adoption and implementation of this EMMP includes:

### 4.1 NATIONAL ENVIRONMENTAL MANAGEMENT ACT, 1998 (NEMA) NEMA P

NEMA provides the overarching legislative framework for environmental governance in South Africa. It establishes the principles, duties and obligations that guide environmental decision-making and ensures that activities are planned and undertaken in a manner that avoids, minimises, mitigates or remedies environmental harm.

NEMA is therefore the primary statute under which this EMMP is prepared. Its provisions apply to all parties involved in the planning, execution, monitoring and management of the proposed maintenance activities, including CapeNature (as the proponent, landowner, implementing agent, and holder of the EMMP, if adopted), contractors, the affected private landowners, service providers, ECOs and auditors.

#### 4.1.1 Section 2: Environmental Management Principles

The Section 2 principles are legally binding and form the foundation of this MMP. Key principles relevant to the maintenance work include:

- Avoidance first: Environmental impacts must first be avoided, and only where avoidance is not possible may minimisation, rehabilitation or remediation be applied—this is the core hierarchy applied throughout the MMP.
- Duty of care and accountability: All parties involved must apply due diligence and adopt a precautionary approach when interacting with sensitive ecosystems, including watercourses, wetlands and riparian zones.
- Sensitive ecosystems to be protected: Protected Areas, Critically Endangered vegetation, riparian ecosystems and strategic water source areas must be afforded the highest level of protection.
- Disturbance must be limited to existing transformed areas: Where feasible, all activities must remain within existing road footprints or previously disturbed surfaces.
- Polluter pays principle: Any party responsible for pollution or degradation must bear the cost of avoiding, minimising and remedying such harm.
- Intergenerational equity: Infrastructure must be maintained in a way that does not compromise ecological integrity or future use of the Nature Reserves.

---

DRAFT ENVIRONMENTAL MANAGEMENT MAINTENANCE PLAN

---

- Integrated environmental management: Maintenance must consider ecological, hydrological, social and infrastructural factors collectively in order to maintain sustainable functioning of the reserves.

These principles form the basis of the impact management outcomes, mitigation measures, roles and responsibilities, and monitoring requirements within this EMMP.

#### **4.1.2 Section 28: Duty of Care Section 28**

Imposing a general duty of care on any person who causes, has caused, or may cause significant pollution or environmental degradation is important. In the context of this EMMP, the duty of care applies to:

- CapeNature, as proponent and implementing agent executing the works, appointed contractors and sub-contractors, the Employer's Representative / Engineer, the Environmental Control Officer (ECO), and any service provider working within the Nature Reserves.

Under Section 28, these parties must:

1. Take all reasonable measures to prevent environmental degradation.
2. Minimise and rectify impacts that cannot be avoided.
3. Contain and clean up spills, contamination or accidental damage immediately.
4. Rehabilitate affected areas, including watercourses, riparian zones and disturbed vegetation.
5. Cease activities causing harm until adequate mitigation is implemented.
6. Report environmental incidents to the relevant authority when required.

This MMP operationalizes the duty of care by providing the required impact management actions, buffer zones, no-go areas, method statements, and monitoring and reporting requirements.

### **4.1.3 Section 30: Emergency Incidents Section 30 of NEMA**

Emergency provisions in NEMA provide for emergency responses where sudden, unexpected events—such as extreme weather, storm damage, washed-out crossings, or blocked culverts—require urgent intervention.

Although emergency works may proceed without prior written EA (although Section 30A still requires verbal, followed by written agreement from the DFFE), the duty of care principle still applies, and the party responsible is always obliged to:

- prevent pollution as far as possible,
- contain spills,
- notify the Competent Authority,
- ensure sufficient monitoring and control,
- implement reasonable measures to minimise environmental harm, and •
- submit required reports after the incident to ensure that no environmental harm has been caused intentionally.

This EMMP includes a dedicated Emergency Works Protocol to ensure that response actions are lawful, appropriate and environmentally responsible. Relevance of NEMA to the Maintenance Works NEMA applies throughout the full lifecycle of the proposed works because:

- the roads are located entirely within Protected Areas,
- watercourses, wetlands and riparian zones occur adjacent to or roads/tracks to be worked on,
- works are undertaken in ecologically sensitive terrain affected by flooding and erosion, and
- maintenance activities carry inherent risks of sedimentation, contamination, habitat disturbance and alteration of hydrological processes.

The EMMP ensures that all maintenance is consistent with NEMA obligations and that CapeNature (as the proponent, landowner, implementing agent, and holder of the EMMP, if adopted) meet their legal responsibilities under the Act. 2.2 EIA Regulations, 2014 (as amended).

The EIA Regulations made under NEMA establish the procedural framework for obtaining environmental authorisation for listed activities that may significantly affect the environment. These regulations identify when an EMMP must be adopted by the Competent Authority, how maintenance activities must be regulated, and the responsibilities of the proponent and implementing agent in ensuring legal compliance. Road maintenance within Protected Areas and watercourses, such as the activities proposed under this EMMP, falls within the scope of the EIA Regulations. To avoid repeated EIA applications each time maintenance becomes necessary, the Regulations allow an EMMP to be formally adopted by DFFE, enabling ongoing lawful maintenance activities under predefined conditions.

### **4.1.4 Listed Activities Relevant to the Proposed Works**

Although the proposed maintenance and repair works would ordinarily trigger certain 'listed activities' under Listing Notice 1 (GN R.983 of 2014, as amended) and Listing Notice 3 (GN R.985 of 2014, as amended) due to the location of the roads/tracks within Protected Areas, watercourses, and sensitive biodiversity areas, these listed activities do not require a separate

## DRAFT ENVIRONMENTAL MANAGEMENT MAINTENANCE PLAN

Environmental Authorisation (EA) on condition that an EMMP is adopted by the Competent Authority prior to said maintenance/repair work being undertaken.

It remains important to identify and describe the listed activities that would have been triggered in the absence of an adopted EMMP. Their inclusion ensures that:

- the scope of authorised maintenance is clearly defined,
- all environmentally sensitive triggers are acknowledged,
- the MMP provides an appropriate mitigation, management, and monitoring framework, and;
- the Competent Authority adopts the EMMP with full appreciation of the environmental risks and regulatory context.

Accordingly, the following 'listed activities' are relevant to the proposed works and have been considered in the preparation of this EMMP.

Activity No(s):	Provide the relevant <b>Basic Assessment Activity(ies)</b> as set out in <b>Listing Notice 1</b> of the EIA Regulations, 2014 as amended	Describe the portion of the proposed project to which the applicable listed activity relates.
19	<p>The infilling or depositing of any material of more than 10 cubic metres into, or the dredging, excavation, removal or moving of soil, sand, shells, shell grit, pebbles or rock of more than ten cubic metres from</p> <p>(i) a watercourse, but <b>excluding:</b></p> <p>(b) where such activities are for maintenance purposes undertaken in accordance with a <b><u>maintenance management plan.</u></b></p>	<p>The identified existing roads and maintenance tracks for Gamkaberg cross several non-perennial watercourses/tributaries. Due to Gamkaberg being located in a mountainous region, rainfall events result in persistent damage of watercourse crossings and associated infrastructure such as gabions / reno mattresses / tracks / low level crossings / culverts.</p> <p>The purpose of this MMP is for these watercourse crossings to be repaired and for continuous maintenance of such crossings to be permissible.</p> <p>Activities must be confined to the existing disturbed footprint of structures/infrastructure and will not involve the expansion of footprint, or increase in capacity, or changes in the footprint location.</p>
27	<p>The clearance of an area of 1 hectares or more, but less than 20ha of indigenous vegetation, <b>except</b> where such clearance of indigenous vegetation is required for (i) a linear activity or (ii) maintenance purposes undertaken in</p>	<p>Areas alongside the existing roads that require repairs and maintenance in terms of stormwater management and/or clearing of vegetation to restore road infrastructure/structures or low level crossings, or in proximity of watercourses</p>

## DRAFT ENVIRONMENTAL MANAGEMENT MAINTENANCE PLAN

	accordance with a <b>maintenance management plan</b> .	will result in the removal of natural vegetation.  Vegetation regrowth over roads/tracks and alongside roads i.e. road verges, must be trimmed/removed to enable maintenance work and/or roads to become passible once repairs are completed.  Activities must be confined to the existing disturbed footprint of structures/infrastructure and will not involve the expansion of footprint, or increase in capacity, or changes in the footprint location.
Activity No(s):	Provide the relevant <b>Basic Assessment Activity(ies)</b> as set out in <b>Listing Notice 3</b> of the EIA Regulations, 2014 as amended	Describe the portion of the proposed project to which the applicable listed activity relates.
12	The clearance of an area of 300m <sup>2</sup> or more of indigenous vegetation <b>except</b> where such clearance is required for <b>maintenance purposes</b> undertaken in accordance with a <b>maintenance management plan</b> (i) within a critically endangered or endangered ecosystem listed in terms of the NEMBA, (ii) within critical biodiversity areas identified in its bioregional plans, (iv) on land, where at the time of the coming into effect of this Notice or thereafter such land was zoned open space, conservation or had an equivalent zoning or (v) on land designated for protection or conservation purposes in an Environmental Management Framework or Spatial Development Framework adopted by the MEC or Minister,	Areas alongside the existing roads/tracks that require repairs and maintenance in terms of stormwater management on structures/infrastructure and/or clearing of vegetation to restore road infrastructure crossings or in proximity of watercourses will result in the removal of natural vegetation.  Activities must be confined to the existing disturbed footprint of structures/infrastructure and will not involve the expansion of footprint, or increase in capacity, or changes in the footprint location.

**8.3 NATIONAL ENVIRONMENTAL MANAGEMENT: PROTECTED AREAS ACT, 2003 (NEM: PAA)**

The proposed works are located within a Protected Area managed by CapeNature. Section 48 of NEM:PAA restricts activities that may negatively impact the purpose or management objectives of a protected area. Maintenance activities must therefore be consistent with conservation objectives and must not result in ecosystem degradation.

Contractors must adhere to Standard Operating Procedures (SOP) that CapeNature have in place for repair and maintenance work.

## DRAFT ENVIRONMENTAL MANAGEMENT MAINTENANCE PLAN

The approval in terms of **Section 50(5) of NEM:PAA** from CapeNature must be submitted with the Final MMP.

#### 8.4 NATIONAL WATER ACT, 1998 (ACT NO. 36 OF 1998)

The proposed maintenance activities will take place within or in close proximity to watercourses and therefore constitute water uses as defined in Section 21 of the National Water Act, 1998. In addition, the activities will be undertaken within what is deemed the 'regulated area' which covers 100m from watercourses (as a buffer area in which additional care must be taken).

The following water uses are applicable:

- Section 21(c): Impeding or diverting the flow of water in a watercourse; and
- Section 21(i): Altering the bed, banks, course, or characteristics of a watercourse.

In order to lawfully undertake these activities, Water Use Authorisation is required in terms of the National Water Act, 1998 as determined under **General Authorisation (GA)**.

Confluent Consulting has been appointed to facilitate the GA process alongside the EMMP.

## 5 ENVIRONMENTAL BASELINE FOR THE WORK AREAS

Appointed Contractors must understand that the Reserve is a Protected Area. By implication, they must understand why there is an obligation on them to conduct their work in a responsible manner and without causing harm to the receiving environment beyond what is permitted for the repair and maintenance work.

In addition to this EMMP, CapeNature has several standard operating procedures (SOPs) that must be adhered to and the Western Cape Government: Department of Infrastructure's Guideline for maintenance work must be implemented.

SPECIFIC WORK AREA	INTERVENTIONS
Servitude Road	 <p data-bbox="590 1928 1369 2016">Erosion gullies forming from the road due to failing stormwater management infrastructure, undermining shared farm fences with private property owners needing infill and repairs.</p>

## DRAFT ENVIRONMENTAL MANAGEMENT MAINTENANCE PLAN



Existing speed humps with erosion protection gabion structures failing due to blocked culverts/pipes forcing water to top over the road and undercut the gabions. Culverts/pipes to be opened and unblocked as well as eroded/damaged stormwater protection structure to be replaced/repared.



Long sections of gabions and reno mattresses along non-perennial crossings where runoff submerge the road during heavy flow periods. Debris/rocks/boulders/cobbles/sand must be removed from the road surface and supporting stormwater management to ensure accessibility and damaged gabions/reno mattresses to be repaired/replaced or to be replaced with concrete strips/cement drifts as a more sustainable structure within the same road footprint and road capacity.

## DRAFT ENVIRONMENTAL MANAGEMENT MAINTENANCE PLAN

## Road A



Sections of the track crossing non-perennial tributaries where re-surfacing is required to ensure that the track remains passable for visitors/tourist not making use of 4x4 vehicles.



Existing stormwater management structures either gabions or reno mattresses along non-perennial tributaries in need of repair or replacement to avoid erosion of the tracks.

## DRAFT ENVIRONMENTAL MANAGEMENT MAINTENANCE PLAN



Crossing of non-perennial tributaries where existing stormwater pipes are blocked, or have collapsed, resulting in overtopping of the track which then causes overflow to erode the track surface material. Road surface is repeatedly backfilled to make the track passable for vehicles, however such ad hoc repairs are not sustainable. Repairing and restoring the stormwater infrastructure into the EMMP will reduce the need for ad hoc repairs, improve water flow in the system and make it more sustainable, alternatively replacing the rock filled road section with gabions/reno mattresses within the same road footprint and road capacity as a more sustainable intervention.



Existing gabions and reno mattresses at non-perennial crossings in need for repair and/or replacement to ensure road safety and avoid unwanted erosion.

## DRAFT ENVIRONMENTAL MANAGEMENT MAINTENANCE PLAN

## Road B



Several sections of the track contains existing gabions/reno mattresses that are failing due to mesh corroding and rocks breaking loose. The track then sags, resulting in more significant overflow and damage to the track surface.





Non-perennial crossing that gets inundated and the track washes away during high rain events needing repeated backfill and stabilization to ensure that vehicles can traverse the crossing.

## 6 ENGINEERING INTERVENTIONS

Due to variable site conditions along the length of the affected roads/tracks, crossing numerous non-perennial tributaries and watercourses throughout the Reserve, specific interventions will be informed by site specifics, considering hydrology, constructability and logistical constraints. However, the following different interventions are proposed for the affected roads/tracks in the Gamkaberg Nature Reserve to be considered as part of this EMMP:

INTERVENTION	PURPOSE	APPROVALS
<b>Rolling dips/Water Bars</b>	Gravel humps across a road/track to divert runoff from the road surface.  Import gravel humps and place at an angle alignment to divert water gently off the road surface.	General maintenance within road footprint, no approval required.  Ongoing throughout several locations in the Reserve.
<b>Example of rolling dip that require maintenance within the road.</b>		
<b>Concrete/Grass Blocks</b>	Surface existing tyre track (typically 2-spoor) or road surface less than 4m, over erodible, steep or uneven i.e. very rocky terrain	General maintenance within road footprint, no approval required.  Ongoing throughout several locations in the Reserve.
<b>Example of road that has become undrivable due to road surface eroding along rocky/steep terrain, with example of concrete strips to reduce maintenance and ensure that the road is passable.</b>		

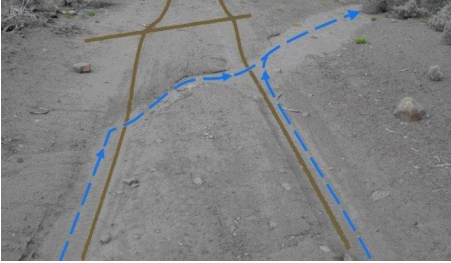
## DRAFT ENVIRONMENTAL MANAGEMENT MAINTENANCE PLAN

<b>Side drains</b>	Unblock/remove silt from existing side drains to improve drainage and keep runoff from eroding the tracks/road surfaces.	General maintenance within road footprint, no approval required. Ongoing throughout several locations in the Reserve.
<b>Example of side drain at roller bar draining into veld (Source: ResearchGate).</b>	 A diagram showing a cross-section of a road surface with a roller bar. A dashed blue line indicates the path of water flowing from the road surface, through the roller bar, and into a side drain on the left. The roller bar is shown as a series of parallel lines.	 A photograph showing a side drain in a natural, vegetated area (veld). The drain is a shallow channel in the ground, with some rocks and debris. The surrounding area is covered with green grass and small shrubs.
<b>Stormwater and erosion prevention structures</b>	Replace and repair broken/blocked stormwater and erosion prevention structures such as reno mattresses/gabions/wing walls/head walls/pipes/culverts to maintain road/track in passable condition.	Removal and reinstatement in a like-for-like basis within regulated areas. EMMP adoption required for working in watercourse and removal of riparian vegetation. Note that no new stormwater / erosion prevention structures will be constructed.
<b>Low Level Crossing</b>	Ensure continued vehicular access over non-perennial watercourses/tributaries with concrete pipes/box culvert transverse to the road, below the existing low-level road slab or gravel surface, with rock pitching/reno mattresses to prevent scour. Water runs underneath/through the structure.	Approximately number for each section in the Reserve: 1. Servitude Road (4) 2. Road A (3) 3. Road B (1) EMMP adoption required for working in watercourse and removal of riparian vegetation. Note that no new low-level crossings will be constructed.
<b>Drifts</b>	Ensure continued vehicular access over non-perennial watercourses/tributaries to withstand seasonal runoff without altering the natural drainage system with rock pitching/reno mattresses to prevent scour by replacing less durable and old gabions/reno mattresses in the drifts with concrete drifts. Most suitable for rugged terrain where high-energy flow tends to cause damage to less durable road	Approximately number for each section in the Reserve: 4. Servitude Road (2) 5. Road A (2) 6. Road B (1) EMMP adoption required for working in watercourse and removal of riparian vegetation.

DRAFT ENVIRONMENTAL MANAGEMENT MAINTENANCE PLAN

	surfaces. Water overtops the structure with high rainfall events.	
<p><b>Gabion/Erosion control structures reconstruction</b></p>	<p>Stabilise/Repair rugged track embankments/slopes with rock filled wire baskets to prevent soil erosion and retain fill or natural slope material to maintain track width and integrity.</p>	<p>Sites with gabion walls:</p> <ol style="list-style-type: none"> <li>1. Servitude Road (+/-86m<sup>2</sup>)</li> <li>2. Road A (+/- 30m<sup>2</sup>)</li> <li>3. Road B (+/- 86m<sup>2</sup>)</li> </ol> <p>EMMP adoption required for removal of vegetation and in proximity to watercourses/regulated area.</p>

The following images show examples of the existing structures that will be subject to repair and maintenance as provided for by the consulting Engineers in as far it is relates to this EMMP:

**6.1 TYPICAL LOW-LEVEL CROSSING DESIGN:**

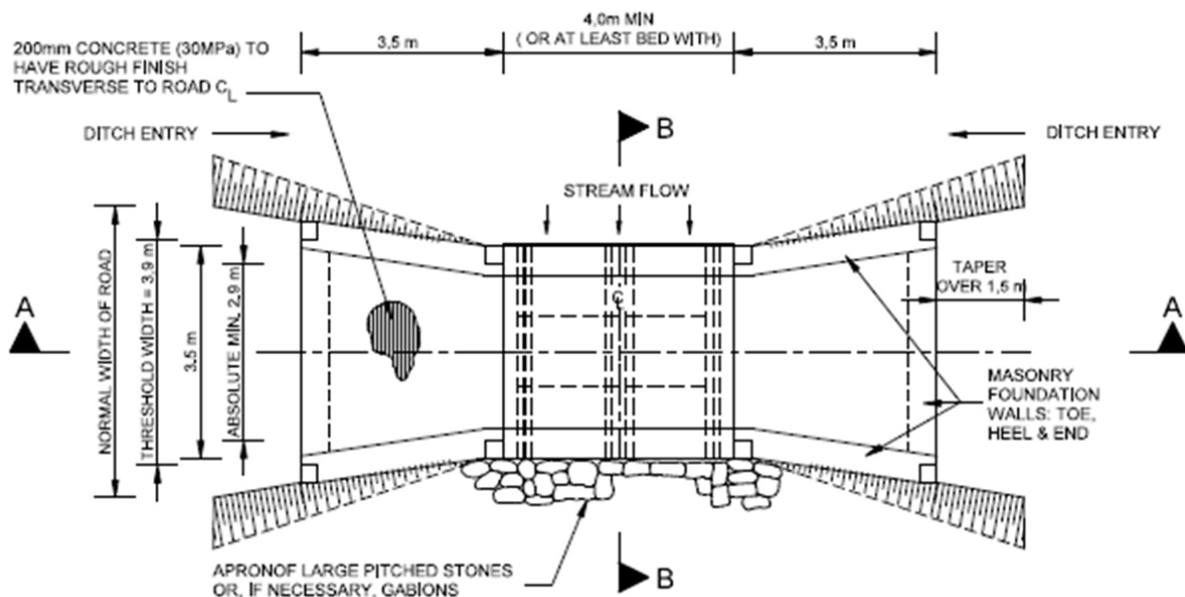

Figure 1: Longitude section of low-level crossing to be repaired and replaced in a like-for-like manner.

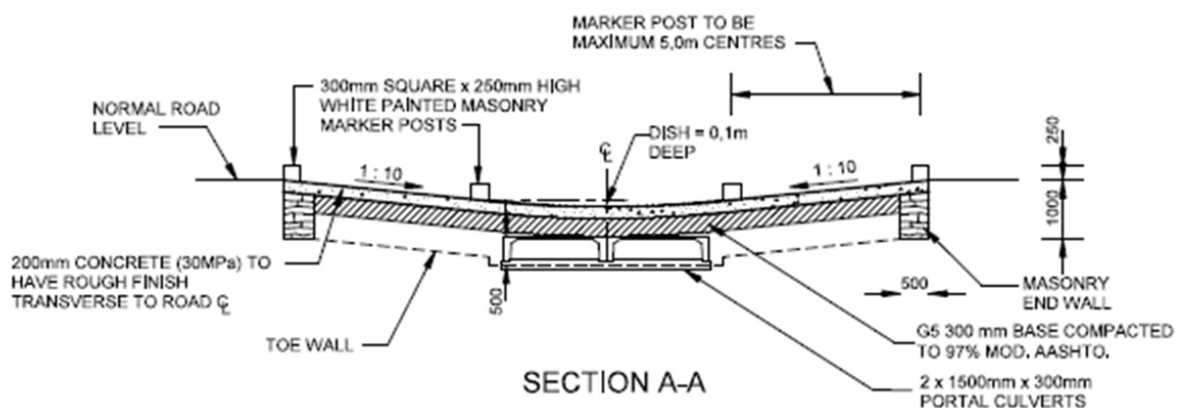

Figure 3: Typical cross section of low-level crossing to be repaired in a like-for-like manner.

DRAFT ENVIRONMENTAL MANAGEMENT MAINTENANCE PLAN

6.2 TYPICAL DRIFT DESIGN:

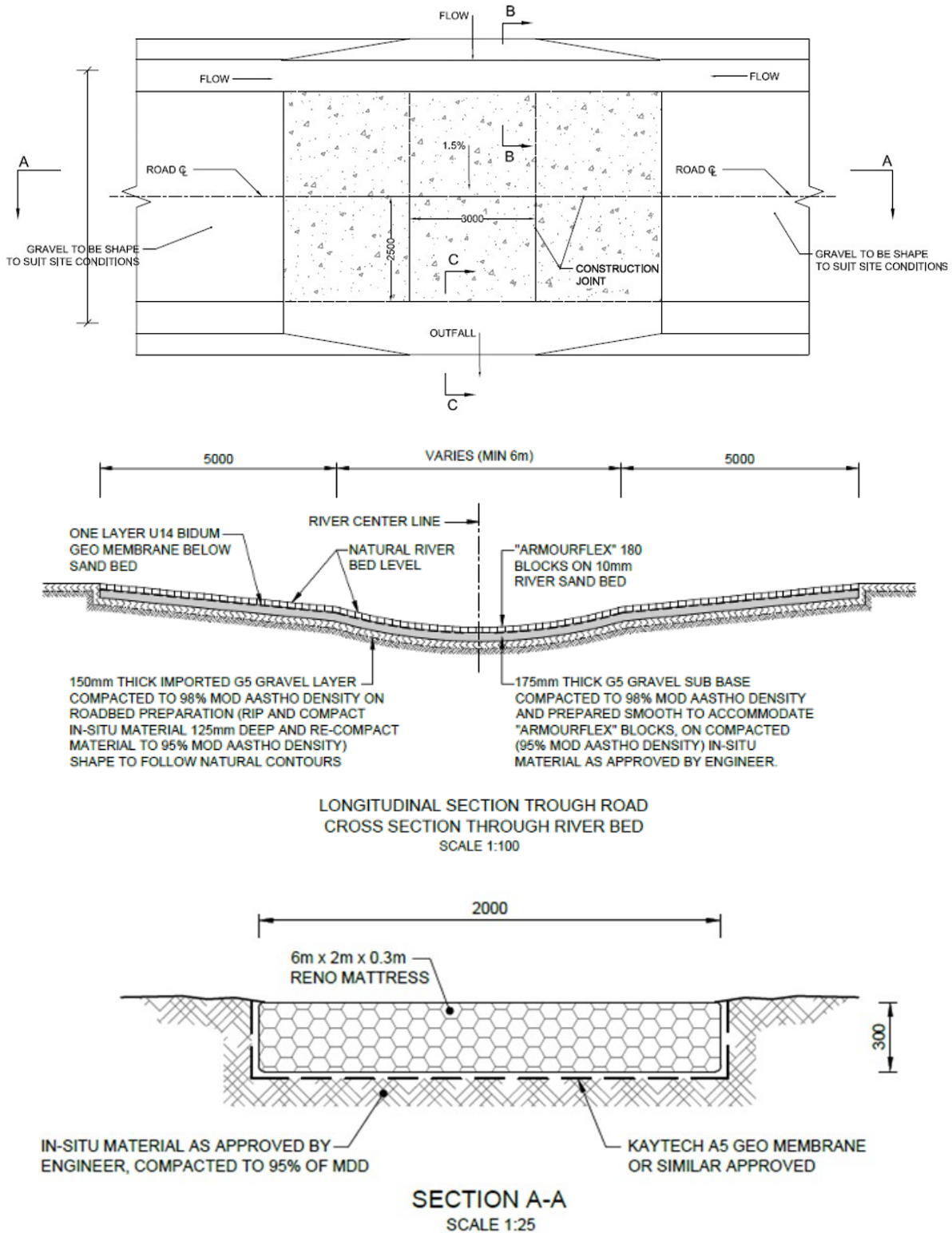

Figure 4: Design for where loose rockfill is used to cross tributaries/watercourses to be replaced with wire baskets (reno mattresses) holding the rockfill in place, in a like-for-like manner.

## DRAFT ENVIRONMENTAL MANAGEMENT MAINTENANCE PLAN

The replacement of loose rockfill, which CapeNature repeatedly has to import, or collect from instream, at multiple crossings of non-perennial tributaries each time there is a high-volume flow / flood, to enable continued functioning of the road/track, is unsustainable.

Anchoring the loose rockfill with wire baskets (reno mattresses) to replacing the loose rockfill, within the same road footprint and same road capacity, in a like-for-like manner, ensures that the rock can be placed in position once, as part of the repair/maintenance, without washing away every time there is substantial flow since the wire baskets will hold the rock in place. This is achieved by making a 300mm excavation in the riverbed to anchor the Reno mattresses. Hydrology will not be impacted since waterflow will continue over/through the reno mattresses.

### 6.3 TYPICAL GABION / CONCRETE REINFORCED STABILISING WALL DESIGN:

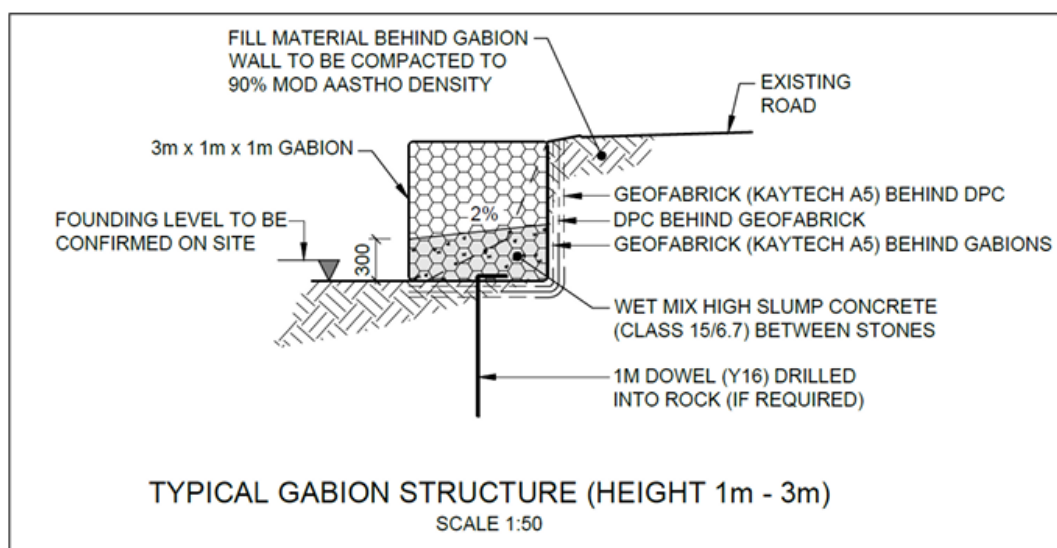

## 7 IMPACT ASSESSMENT AND MANAGEMENT RECOMMENDATIONS

The National Screening Tool provides a mechanism for determining environmental sensitivities at a high level. Sensitivities are *mapped* at a desktop level and therefore not produced from ground-truthed data, however for the purpose of the EMMP the results are indicative and used to determine potential impacts arising from the repair and maintenance work. Site sensitivity verification took place by means of a site inspection by the EAP who was joined by a Reserve Ranger with in-depth knowledge of the receiving environment.

The following potential environmental sensitivity themes have been identified for the different sections in the Reserve and impacts are discussed according to these themes. Notably some of the sensitivities differ between the different sections, mostly on the 'Agricultural' and 'Civil Aviation' themes which as deemed to not be applicable having a very low to negligible sensitivity associated with repair/maintenance work.

## DRAFT ENVIRONMENTAL MANAGEMENT MAINTENANCE PLAN

Table 3: Screening Tool sensitivities – Gamkaberg Nature Reserve

Theme	Very High sensitivity	High sensitivity	Medium sensitivity	Low sensitivity
Agriculture Theme	X			
Animal Species Theme		X		
Aquatic Biodiversity Theme	X			
Archaeological and Cultural Heritage Theme				X
Civil Aviation Theme		X		
Defence Theme				X
Paleontology Theme	X			
Plant Species Theme		X		
Terrestrial Biodiversity Theme	X			

### 7.1 POTENTIAL RISKS AND IMPACTS

Although noted in by the Screening Tool, it is submitted that the following themes are deemed not applicable either through usage, or zoning, and no risks/impacts are associated with these themes namely Agriculture (functioning as a protected area and nature reserve with no agricultural land use), defence, civil aviation, as well as heritage/archaeology are not impacted in any manner by road maintenance.

- Based on the Screening Tool outcome, the Agriculture theme is categorised as ‘High’ which relates to the existing agricultural production areas that fall outside of the proclaimed Gamkaberg Nature Reserve. Only a portion of the Servitude Road section where maintenance is necessary (main access to the Reserve) traverses this farmland.
- Defence/Civil Aviation is not affected by repair and maintenance on exiting roads in a like-for-like manner.
- Heritage/Archaeology is mapped as having ‘Low’ sensitivity considering that the affected work areas are far/separated from where known features are within the Reserve.

#### 7.1.1 Animal Species – High sensitivity (all sections)

Bird, insect, reptile and mammal species are listed as potentially sensitive and/or unique which is expected for a nature reserve under conservation management.

Repair and maintenance activities are proposed to take place within existing road and track footprints with associated structures and infrastructure such as gabions, side drains, stormwater structures, wingwalls, head walls etc. Although work will entail disturbance inclusive of vegetation removal/trimming supporting animal habitat, the repair and maintenance work is of a temporary nature, limited in scope and extent. Work areas will be monitored by an appointed Environmental Control Officer (ECO) on a monthly basis and by experienced CapeNature rangers on a regular basis.

Potential impacts that may impact on fauna species include:

- Limited removal of vegetation/affecting habitat to access working areas
- Temporary noise impacts associated with Contractor teams and machinery
- Possibility of poaching / Harming of fauna

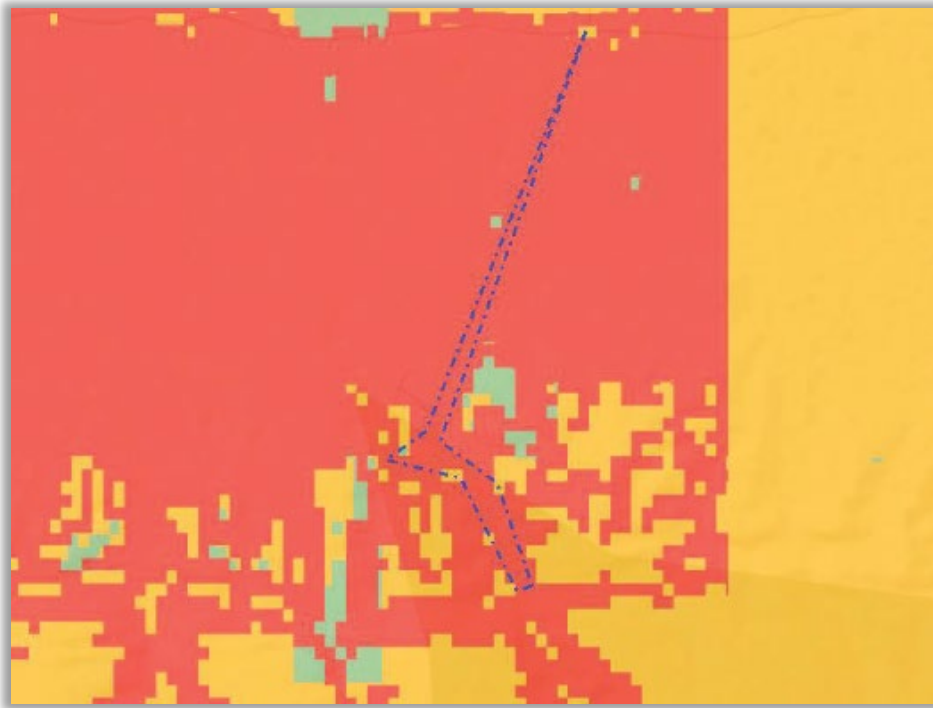

Figure 5: Faunal sensitivity categorised as 'High' into the Screening Tool.

The appointed Contractor will be briefed by CapeNature and formal Environmental Induction will be scheduled by the appointed ECO to ensure that workers are aware of the protected status of the environment they will be working in.

Under these controlled conditions, search and rescue of fauna is possible prior to, as well as during repair/maintenance works.

Very limited and only temporary impacts are anticipated which will be within acceptable limits.

### 7.1.2 Aquatic Biodiversity – Very High sensitivity

The Reserve falls within the greater Gouritz Water Management Area (WMA) more specifically, the Olifants River sub-catchment. The tributaries flowing through the Reserve, drain the lower slopes and mountains of the surrounding areas towards the sub-catchment and Olifants River.

Due to the low rainfall and the resulting semi-arid to arid nature of the area, the smaller tributaries and streams flowing through the Reserve, are seasonal (or non-perennial), and in some cases ephemeral, with dry water courses.

Due to drainage towards and proximity of the Olifants River and its flood plain, the sensitivity rating of Very High is to be expected, since the tracks follow and traverse some of the non-perennial streams, therefore aquatic habitats will be temporarily disturbed during repairs and maintenance of crossings and where repair work will be undertaken in proximity to a natural watercourse.

Due to the arid climate with most watercourses being dry most of the time, repair work within watercourses can be restricted to dry period to minimise disturbances.

## DRAFT ENVIRONMENTAL MANAGEMENT MAINTENANCE PLAN

The following potential impacts/risks have been identified:

- Temporary modification of streambeds and banks during earthworks / moving of material / removing of structures/infrastructure and/or installation of structures/infrastructure;
- Temporary increase in sedimentation (noting however that watercourses in the Reserve are mostly seasonal therefore work can be scheduled during dry periods);
- Short-term water quality impairment (noting however that watercourses in the Reserve are mostly seasonal therefore work can be scheduled during dry periods);
- Temporary erosion risk associated with working along watercourse banks;
- Long-term reduction of erosion potential once structures is repaired and functional;
- Potential for spills of fuel i.e. diesel / oil in the riparian areas when machinery work in the area;
- Improved hydrological functioning when blocked/damaged culverts/pipes are repaired/replaced;
- Reduced need for repeated maintenance in watercourses once infrastructure is repaired in a more sustainable manner.

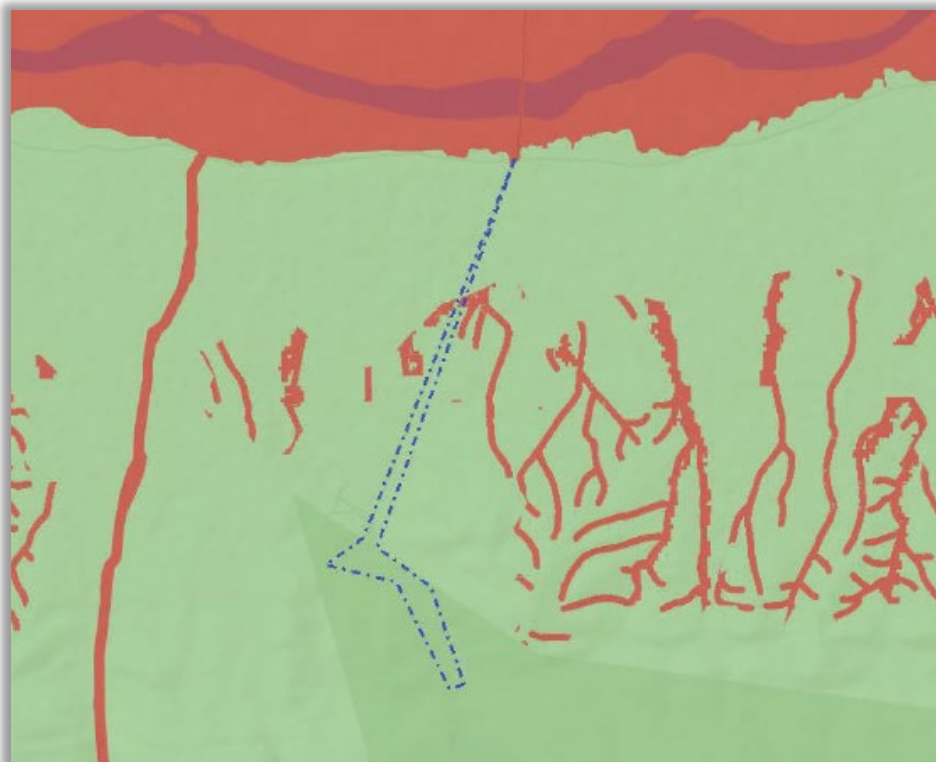

Figure 6: Aquatic sensitivity classified as 'Very High' due to proximity to the Olifants River north of the Gamkaberg Nature Reserve, as well as non-perennial stream crossings along the road/tracks (Source: Screening Tool).

The appointed Contractor will be briefed by CapeNature and formal Environmental Induction will be scheduled by the appointed ECO to ensure that workers are aware of the protected status of, as well as the sensitivities of the aquatic environment they will be working in.

Work areas will be monitored by an appointed Environmental Control Officer (ECO) on a monthly basis and by experienced CapeNature rangers on a regular basis.

Under such controlled conditions, impacts are temporary and within acceptable limits.

### 7.1.3 Palaeontology – Very High

The Gamkaberg Nature Reserve is declared World Heritage Site due to the reserve's history which includes Khoisan occupation, as well as early Trekboer routes. The Reserve is also rich in Khoisan rock art and stone age paintings, albeit deeper south into the Reserve (along mountainous hiking trails), as well as early marine invertebrate fossils.

The screening tool sensitivity is therefore not disputed given the presence of these features and the entire Gamkaberg Nature Reserve being a World Heritage Site. However, the existing tracks and main access road are located far from these mapped features which are historic and therefore continued repair and maintenance of these roads/tracks will not introduce new impacts or exacerbate existing impacts on such features.

Potential impacts associated with cultural heritage/archaeology/palaeontology include:

- Permanent damage to exposed features (ruins / quartz fields etc) when working in proximity to identified features i.e. vehicles driving outside of designated work areas / collecting materials.

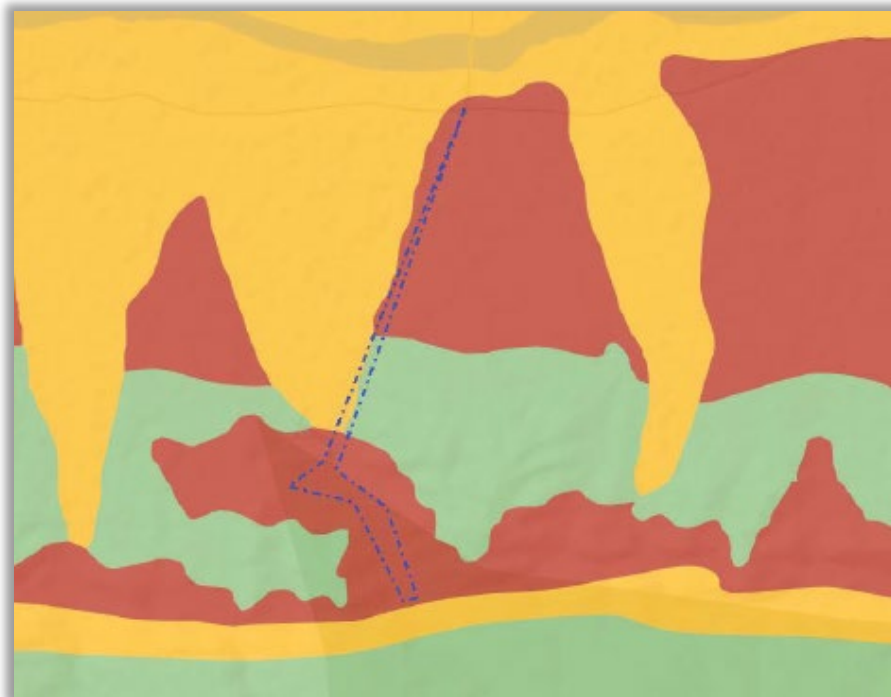

Figure 7: Mapped paleontological sensitivity areas overlapping with the study area (Source: Screening Tool).

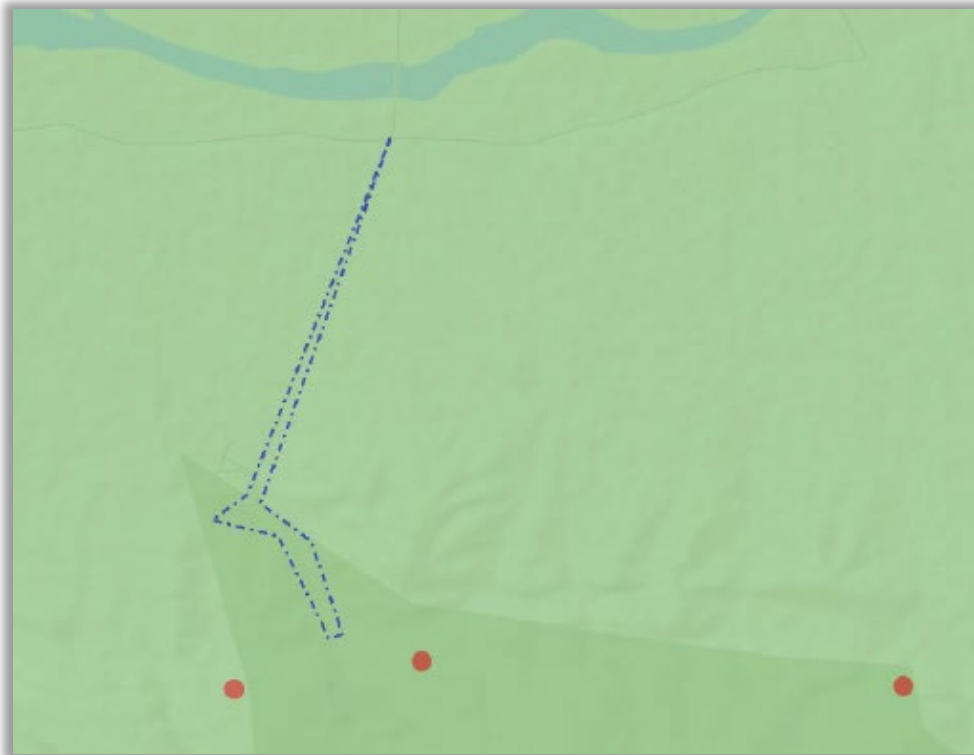

Figure 8: Mapped heritage/archaeological features in the Reserve cultural landscape (Source: Screening Tool).

#### 7.1.4 Plant species – High | Terrestrial Biodiversity – Very High

Several plant species within the Reserve are deemed sensitive with many recorded as priority species of conservation concern (SCCs) that include some Critically Endangered, Endangered, Vulnerable, Near Threatened, Data Deficient, Rare and Critically Rare species. This is expected from an area under conservation management.

The focus area of highest flora sensitivity is in the area of Road B which provides access to the Gamkaberg Nature Reserve offices and staff accommodation.

Due to the location of work areas being within a protected area, the very high sensitivity rating for terrestrial biodiversity is evident because it does form part of a critical biodiversity area (CBA).

Potential impacts associated with impact on plant species / biodiversity include:

- Limited vegetation clearing within work areas, as well as vegetation trimming alongside roads/tracks to enable workers/machinery access;
- Trampling and damage to vegetation by workers, including heavy vehicles driving off the existing road/track to pass each other (roads/tracks are very narrow);
- Poaching of plants (especially succulents);
- Increased risk of alien vegetation regrowth following disturbance.

DRAFT ENVIRONMENTAL MANAGEMENT MAINTENANCE PLAN

---



Figure 9: Mapped 'high' sensitivity areas in proximity to the road/track working areas for Road B.



Figure 10: Terrestrial biodiversity mapped as 'very high' sensitivity for the majority of the study area where road repairs are necessary.

---

DRAFT ENVIRONMENTAL MANAGEMENT MAINTENANCE PLAN

---

Regular monitoring by CapeNature rangers in areas where repair/maintenance work will take place, as well as the formal Induction by the appointed ECO, will point out that workers may not wander beyond their working areas into the veld and they may not collect any plants or harm any animals.

Considering that the repairs and maintenance work are on existing roads/infrastructure where habitat has already been transformed / previously disturbed during construction / maintenance activities, the impacts are expected to be localized, temporary and reversible.

## **7.2 IMPACT MANAGEMENT ACTIONS AND OUTCOMES**

Considering the potential impacts and risks that have been identified, this EMMP considers both '**environmental actions**' as well as '**environmental outcomes**' as part of the measures to ensure impacts are minimised and/or mitigated effectively.

For the purpose of the MMP the EAP has considered:

- The receiving environment in which repair and maintenance work will be performed;
- The engineering interventions proposed for repair and maintenance (refer to Section 10 of this report);
- Evaluate the potential impacts and considered best practice to minimise / mitigate.

The following 'action' and 'outcomes' are summarised based on the above criteria.

## DRAFT ENVIRONMENTAL MANAGEMENT MAINTENANCE PLAN

Intervention	Resource	Potential Risk/Impact	Management Action (mitigation measure)	Management Outcome
Stormwater and erosion prevention structures	Slopes & embankments of watercourses / Hydrology / watercourses / riparian habitat / aquatic biodiversity	Siltation (sediment) Temporary disturbance of aquatic habitat Unwanted erosion	<ul style="list-style-type: none"> <li>• Prioritise work during dry months and/or low-flow periods</li> <li>• Conduct work by hand where possible and limit machinery to the minimum</li> <li>• When excavating in riverbed, loose material must be placed upstream of the structure if not outside the riparian area</li> <li>• Make use of silt traps, sandbags and/or erosion barriers during repairs/maintenance</li> <li>• Repair any erosion gulleys that may form during repair work</li> <li>• Ensure that machinery used to work in proximity to watercourses or in watercourse do not leak oil/fuel</li> <li>• Any mixing of concrete/cement must be done outside of the riparian area and area must be properly bunded</li> <li>• Ensure that work is done on a like-for-like basis to avoid increasing the permanent footprint beyond the status quo.</li> <li>• Stockpile broken / unusable materials outside of the riparian area</li> </ul>	<p>Improve hydrological functioning and stormwater performance.</p> <p>Reduce unsustainable maintenance.</p> <p>Extend lifespan and improve condition of the road/tracks.</p> <p>Improve accessibility for rangers using management tracks for alien clearing / fence management / species monitoring and fire management.</p>

## DRAFT ENVIRONMENTAL MANAGEMENT MAINTENANCE PLAN

Intervention	Resource	Potential Risk/Impact	Management Action (mitigation measure)	Management Outcome
			<ul style="list-style-type: none"> <li>Stockpile new materials outside of the riparian area</li> </ul>	
Low-level crossings / Drifts	Slopes and embankments of watercourses / Hydrology / watercourses / riparian habitat / aquatic & terrestrial biodiversity	Siltation (sediment) Temporary disturbance of aquatic habitat Unwanted erosion Temporary disturbance of terrestrial habitat	<ul style="list-style-type: none"> <li>Prioritise work during dry months and/or low-flow periods</li> <li>Conduct work by hand where possible and limit machinery to the minimum</li> <li>When excavating in riverbed, loose material must be placed upstream of the structure if not outside the riparian area</li> <li>Make use of silt traps, sandbags and/or erosion barriers during repairs/maintenance</li> <li>Repair any erosion gulleys that may form during repair work</li> <li>Ensure that machinery used to work in proximity to watercourses or in watercourse do not leak oil/fuel</li> <li>Use temporary water diversion where necessary and restore flow once repairs have been completed</li> <li>Any mixing of concrete/cement must be done outside of the riparian area and area must be properly bunded</li> <li>Ensure that work is done on a like-for-like basis to avoid increasing</li> </ul>	<p>Reduce unsustainable maintenance.</p> <p>Extend lifespan and improve condition of the road/tracks.</p> <p>Improve accessibility for rangers using management tracks for alien clearing / fence management / species monitoring and fire management.</p>

## DRAFT ENVIRONMENTAL MANAGEMENT MAINTENANCE PLAN

Intervention	Resource	Potential Risk/Impact	Management Action (mitigation measure)	Management Outcome
			<p>the permanent footprint beyond the status quo.</p> <ul style="list-style-type: none"> <li>• Stockpile broken / unusable materials outside of the riparian area</li> <li>• Stockpile new materials outside of the riparian area</li> </ul>	
Gabion walls & Cement stabilising	Slopes and embankments of watercourses / hydrology / watercourses / riparian habitat / aquatic & terrestrial biodiversity	<p>Siltation (sediment)</p> <p>Temporary disturbance of aquatic habitat</p> <p>Unwanted erosion</p> <p>Temporary disturbance of terrestrial habitat</p>	<ul style="list-style-type: none"> <li>• Prioritise work during dry months and/or low-flow periods</li> <li>• Conduct work by hand where possible and limit machinery to the minimum</li> <li>• When excavating in riverbed, loose material must be placed upstream of the structure if not outside the riparian area</li> <li>• Make use of silt traps, sandbags and/or erosion barriers during repairs/maintenance</li> <li>• Repair any erosion gulleys that may form during repair work</li> <li>• Ensure that machinery used to work in proximity to watercourses or in watercourse do not leak oil/fuel</li> <li>• Use temporary water diversion where necessary and restore flow once repairs have been completed</li> <li>• Any mixing of concrete/cement must be done outside of the</li> </ul>	<p>Reduce unsustainable maintenance and improve sustainable structures/infrastructure.</p> <p>Protect the road integrity and ensure continued accessibility.</p> <p>Improve accessibility for rangers using management tracks for alien clearing / fence management / species monitoring and fire management.</p>

## DRAFT ENVIRONMENTAL MANAGEMENT MAINTENANCE PLAN

Intervention	Resource	Potential Risk/Impact	Management Action (mitigation measure)	Management Outcome
			<p>riparian area and area must be properly bunded</p> <ul style="list-style-type: none"> <li>• Ensure that work is done on a like-for-like basis to avoid increasing the permanent footprint beyond the status quo.</li> <li>• Stockpile broken / unusable materials outside of the riparian area</li> <li>• Stockpile new materials outside of the riparian area</li> </ul>	
Removal and disturbance of vegetation (brush cutting / trampling / removal of vegetation encroaching onto road/tracks)	Terrestrial biodiversity	<p>Temporary disturbance and loss of vegetation that may expose areas to unwanted erosion</p> <p>Localised disturbance to terrestrial and aquatic vegetation during construction.</p> <p>Poaching of plants /animals (especially succulents/reptiles)</p> <p>Re-occurrence of invasive alien vegetation in disturbed areas.</p> <p>Construction vehicles driving outside the</p>	<ul style="list-style-type: none"> <li>• Restrict vegetation removal to minimum by giving preference to working by hand where possible and only clearing what is absolutely necessary to enable machinery to access a work area</li> <li>• Biomass may not be left in the watercourses, but must be removed and either chipped / used as brush pack material for rehabilitation and stabilising of exposed soil</li> <li>• Stockpiling of material and/or site camps may not be done in areas containing intact natural vegetation</li> <li>• Workers must remain within the designated work area and may not wander into the adjoining natural veld</li> </ul>	<p>Limit loss of vegetation and habitat destruction</p> <p>Minimise impact to temporary nature</p> <p>Ensure that areas do not remain exposed post rehabilitation</p>

## DRAFT ENVIRONMENTAL MANAGEMENT MAINTENANCE PLAN

Intervention	Resource	Potential Risk/Impact	Management Action (mitigation measure)	Management Outcome
		road/tracks when needing to bypass, make narrow turns, or where dedicated turning areas are far apart and vehicles such as graders cannot make narrow bends.	<ul style="list-style-type: none"> <li>• Site camp selection / stockpile areas must be agreed with the ECO and/or CapeNature Rangers in advance and demarcated appropriately</li> <li>• CapeNature Ranger / ECO must clearly identified and mark designated turning areas and stockpile areas prior to repair/maintenance work commencing</li> <li>• Drivers may not drive into the natural vegetation / veld to turn-around or park unless it is within a designated area as agreed with the CapeNature Rangers or ECO</li> <li>• Workers must be briefed on the fact that work is undertaken within a Protected Area and that poaching / damaging fauna is not permitted</li> <li>• Rehabilitate affected work areas by reinstating topsoil, reshaping riverbanks, replanting or seeding with local indigenous species in affected areas under guidance of CapeNature and/or the ECO</li> </ul>	
Impact on fauna (terrestrial and aquatic)	Terrestrial / Aquatic biodiversity	Temporary disturbance to fauna making use of watercourses for	<ul style="list-style-type: none"> <li>• Limit the use of heavy machinery to reduce noise levels</li> </ul>	Avoid unnecessary or long-term impact on

## DRAFT ENVIRONMENTAL MANAGEMENT MAINTENANCE PLAN

Intervention	Resource	Potential Risk/Impact	Management Action (mitigation measure)	Management Outcome
		<p>drinking or as corridors for movement</p> <p>Poaching of animals</p> <p>Injury to animals</p>	<ul style="list-style-type: none"> <li>• Ensure that workers remain within the work area to prevent entering into remaining natural areas</li> <li>• No animal poaching permitted</li> <li>• Any injured animals must be captured and reported/delivered to the CapeNature office</li> <li>• Refrain from exceeding speed limits and ensure that all vehicles are licenses with drivers having the necessary permits/licenses to operate vehicles</li> <li>• Workers must be briefed on the fact that work is undertaken within a Protected Area and that poaching / damaging fauna is not permitted</li> <li>• Workers must keep food / drinks in containers/closed-up to prevent animals such as baboons / monkeys / jackal etc from accessing such items</li> <li>• All food items / waste must be collected on a daily basis and must be removed from the work area on a daily basis to prevent littering</li> </ul>	fauna and supporting habitat
Impact on cultural heritage / archaeology / palaeontology	Heritage / Landscape	Possible damage to sites / features described as having heritage value	<ul style="list-style-type: none"> <li>• Contractors may not leave behind any building / construction materials such as sandbags / concrete mix / gravel piles / pipes /</li> </ul>	Achieve no-impact level on archaeological features in the study area

## DRAFT ENVIRONMENTAL MANAGEMENT MAINTENANCE PLAN

Intervention	Resource	Potential Risk/Impact	Management Action (mitigation measure)	Management Outcome
		Building rubble/material left behind by Contractors detracting from the scenic and natural landscape	<p>cement slabs / wire baskets from old gabions/reno mattresses / culverts etc – all such materials must be collected and disposed of at a registered landfill site, or re-used by the Reserve management in a responsible manner</p> <ul style="list-style-type: none"> <li>• Workers may not drive outside of dedicated roads / tracks unless authorised by CapeNature Rangers / ECO or within designated turning areas or passing bays</li> <li>• Stockpiles of material and/or site camps must be in areas agreed with CapeNature / ECO</li> <li>• Workers must be briefed on the importance of heritage features to know that they may not damage such features</li> </ul>	

DRAFT ENVIRONMENTAL MANAGEMENT MAINTENANCE PLAN

---

### 7.3 GENERAL MANAGEMENT CONDITIONS

In addition to the impact specific management actions and outcomes, it is important for the Contractor to also adhere to the following general conditions to ensure that the repair/maintenance work does not result in unwanted environmental impacts:

- Designated **temporary passing bays** and **turning areas** for large construction vehicles must be identified in collaboration with CapeNature Rangers and/or the ECO prior to work starting on a specific section of road/track;
  - In all instances, these areas must be recorded for continuous monitoring and rehabilitated of the affected area once a specific section of road/track is finished with repairs;
- Already **disturbed areas must be prioritised** for the designated temporary passing bays/turning areas rather than untransformed, intact natural areas where possible;
- All designated temporary passing bays and turning areas must be clearly **marked** (consider the use of large rocks / painted wooden pole that are visible to drivers in elevated vehicles), however Contractor must refrain from using plastic materials such as candy stripe danger tape that can easily get ripped/blown away/cause harm to animals;
- In the event where the general public, or tourists travel along any of the road sections under repair, the Contractor must ensure that **stop-go measures, or a flag-person, or signage, or a combination of these measures**, are implemented to prevent the public from driving into the adjacent natural veld in order to avoid, or bypass construction vehicles during the maintenance periods;
- Fynbos is a fire prone vegetation type, therefore workers may **only smoke in designated areas** and may **not dispose of cigarettes** anywhere other than specific containers that may be provided for by the Contractor at all work areas;
- **No open fires** are permitted at any of the work areas;
- Workers must **make use of ablution facilities** i.e. mobile toilets which the Contractor must provide for at each working area within a designated location that may not be within the riparian area or watercourses;
- The Contractor must ensure that the **mobile ablution facilities are kept functional at all times** and is **cleaned out regularly** to ensure that workers are able and willing to make use of the facility;
- **Toilet tanks from mobile ablution facilities** may not be emptied, or the content disposed of anywhere other than a toilet i.e. at the Gamkaberg offices, or must be removed off-site for disposal at a wastewater treatment works;
- Workers **may not relieve themselves in the veld / natural vegetation** and must make use of the ablution facilities provided by the Contractor;
- Any **contaminated sand/soil/material from machinery** (oil / fuel / cement or concrete mixture) must be collected by the Contractor immediately after and the contaminated

---

DRAFT ENVIRONMENTAL MANAGEMENT MAINTENANCE PLAN

---

material must be kept separate to be disposed of according to hazardous material protocols and may not be disposed of in the Reserve;

- Work materials (broken / used etc) **may not be discarded** anywhere in the Reserve and must be contained in a secure area as agreed with CapeNature / ECO for regular removal from the Reserve and lawful disposal;
- Stationary vehicles must be **fitted with drip trays** and collected materials from drip trays must be kept separate and must be disposed of according to hazardous material protocols and may not be disposed of in the Reserve;
- Any machinery that require refuelling on the Reserve must do with in **bunded / sealed surface areas** and any spills handled according to hazardous material protocols and may not be disposed of in the Reserve;
- **No works stipulated in this EMMP may commenced** until such time as the EMMP is formally adopted and the necessary General Authorisation (GA) is obtained from the Breede-Olifants Catchment Management Agency (specifically for work in regulated areas).
- An **Environmental Control Officer (ECO)** must be appointed prior to any repair/maintenance work stipulated in terms of this EMMP and must conduct regular inspection and report on works to the DFFE and CapeNature;
- The Contractor must ensure compliance with relevant **Standard Operating Procedures** that CapeNature has for maintenance/work within the Reserve;
- The Contractor must ensure compliance with the **Western Cape Government: Department of Infrastructure Standards**.

## 8 MONITORING, REPORTING & INDICENTS

Once adopted, this EMMP must be implemented by CapeNature and all responsible parties that may be involved, including the Resident Engineer, Contractor, Workers, Rangers and ECO.

For the purpose of this EMMP a distinction is made between an 'incident' and 'non-compliance':

INCIDENT	NON-COMPLIANCE
An incident is a sudden, unexpected event that occurs without warning and is outside a party's reasonable control, often causing damage, loss, or disruption. These unforeseen occurrences cannot be prevented or anticipated through normal planning and compliance.	When a reasonable person could anticipate, predict, or expect an accident to occur as a consequence of a specific action, inaction or negligence where the risk was known, or should have been known.
<i><u>Example:</u> Vehicle gets a flat tyre that requires additional vehicles to provide support in close proximity, or to off-load onto another vehicle, resulting in temporary disturbance of natural vegetation alongside the road.</i>	<i><u>Example:</u> Ignoring dedicated turning areas for vehicles along a specified route and instead turning around outside of a dedicated turning area with vehicles resulting in damage to vegetation and/or aquatic habitat.</i>

- Due to the remote location of the Reserves where there is limited reception and no offices at the work sites, it is therefore highly recommend that the RE setup a communication platform such as a WhatsApp group that as a minimum, must consist of the RE, Contract Manager, the Health & Safety Officer, the Environmental Control Officer and the Reserve Manager responsible for overseeing the repair & maintenance once site hand over has taken place. Record from this communication platform must be available for compliance monitoring at all times.

### 8.1 INCIDENTS & REPORTING

The most likely occurrences of damage to vegetation, or aquatic habitat, when conducting repair work, is likely to be associated with **movement of large vehicles** transporting heavy loads and where they leave the tracks/road, or vehicles driving outside of **designated turning locations**. Vehicles in use, may include graders / tipper trucks / rollers and/or excavators needed to transport materials and / or move materials/structures/infrastructure for repairs and maintenance.

Due to the fact that the terrain where repairs works are required is sometimes steep, the tracks very narrow and/or work or surrounding areas may be wet/slippery, the potential for vehicle

## DRAFT ENVIRONMENTAL MANAGEMENT MAINTENANCE PLAN

slips is high and the reality is that larger vehicles cannot pass on the narrow roads unless there are designated passing bays and/or turning areas.



Figure 11: Example of where large vehicles pass each other on a narrow track.



Figure 12: Example where grader drives off the road to make a u-turn or get out of the way of oncoming traffic.



Figure 13: Example of temporary designated passing bay along narrow track to enable large construction vehicles to pass each other. Area must be clearly marked and rehabilitated once repair work is completed.



Figure 14: Example of area packed with large rocks and branches to support regrowth in an area where construction vehicles deviated from the designated turning and passing bays.

- The Contractor must immediately notify the RE of any such incident/deviation from EMMP stipulations, where vegetation or aquatic habitat have been noticeably damaged;
- When reporting to the RE, the Contractor must do so with detailed photographic record (photos taken from multiple angles to clearly show the extent of the damage and also an indication of where along which route the incident happened)<sup>2</sup>;
- The RE (or Contractor) must post all environmental incident on the official project communication platform (WhatsApp is advisable) to ensure complete record that can be traced for compliance purposes;
- The ECO must provide input to the RE in terms of rehabilitation requirement, who must then issue formal site instructions to the Contractor for corrective measures;

---

DRAFT ENVIRONMENTAL MANAGEMENT MAINTENANCE PLAN

---

- The Contractor must ensure that the corrective measures are implemented to the satisfaction of CapeNature and the ECO;
- The RE must determine whether an incident/deviation from specifications of this EMMP demands a fine or withholding of (%) payment, in addition to the financial responsibility associated with rehabilitation measures;
- The ECO must report on all recorded incidents and report on such, inclusive of remedial actions, as well as rehabilitation status, in the monthly report.

## **8.2 ROLE AND RESPONSIBILITY OF THE ECO**

- Integrate environmental considerations into the planning and execution of all maintenance and repair activities under this EMMP.
- Ensure that roles, responsibilities and lines of accountability for environmental management are explained to the Contractor responsible for implementing the EMMP.
- Ensure that all contractors, reserve staff and implementing agents understand and comply with the environmental measures contained in this EMMP.
- Continuously advise on best practice to avoid, minimise and where necessary rehabilitate impacts on watercourses, riparian areas, terrestrial biodiversity, soils, slopes and hydrological processes.
- Ensure maintenance activities are confined to existing disturbed footprints, avoiding encroachment into intact indigenous vegetation and that repair/maintenance work is done in a like-for-like scenario.
- Ensure that maintenance activities contribute to the long-term functioning of ecological infrastructure, including natural drainage systems, bank stability, riparian vegetation and habitat integrity.
- Ensure that adequate record-keeping, monitoring and reporting systems are in place to verify compliance and guide adaptive management.
- Promote the development and implementation of method statements that align with ecological processes, hydrological function, reserve management requirements and NEMA's duty-of-care obligations.
- Any non-compliance or environmental incident to be reported to the Resident Engineer, Contractor and CapeNature and rectified with immediate effect.
- The ECO must advise the RE when deviation/incidents are considered non-compliance that may require that a Fine be issues or that Payment of the Contractor should be withheld.

---

DRAFT ENVIRONMENTAL MANAGEMENT MAINTENANCE PLAN

---

- The Contractor must submit Method Statements for all activities requiring environmental controls including, but not limited to:
  - Demarcating of temporary passing bays / turning areas
  - Cleaning of Culverts / low-level crossings / drifts
  - Repairing of culverts/stormwater infrastructure / headwalls / wingwalls / gabions/ reno mattresses
  - Reshaping of embankments
  - Like-for-like replacement of structures/infrastructure in watercourses
  - Repair / replace of grass blocks / interlocking blocks / cement strips in watercourses
  - Clearing or trimming of vegetation (overgrown roads/tracks and watercourses)
  - Erosion control
  - Site Camp selection and setup

### 8.3 FREQUENCY OF INSPECTIONS

CapeNature operates under their own Protected Areas Environmental Management Plan as well as internal Standard Operating Procedures (SOPs) that enables and empowers Rangers with the necessary knowledge to assist with on-site monitoring for the duration of the maintenance contract.

It is anticipated that CapeNature will have representation at work areas on a regular basis to prevent unwanted damage to the receiving environment and ensure the safety of their staff and visitors alike.

In light of the presence of Rangers who will be overseeing repair/maintenance work at the Reserve regularly, it is recommended that the appointed **ECO conduct site inspections on a monthly basis.**

However, if the ECO finds that the Contractor is non-compliant with the EMMP and/or conditions of adoption thereof, ECO inspections may be increased in consultation with CapeNature.

### 8.4 REPORTING

---

DRAFT ENVIRONMENTAL MANAGEMENT MAINTENANCE PLAN

---

The ECO must report on progress with the repairs/maintenance on a monthly basis and in written format.

Monthly monitoring reports must be submitted to the DFFE and CapeNature monthly and as a minimum, must report on:

- Site inspections
- Maintenance/repair activities undertaken
- Environmental performance of the Contractor
- Incidents / Non-compliance / Corrective actions
- Rehabilitation progress of affected (temporary) passing bays, turning areas and site camp once repairs are finished in a specific area
- Recommendations for improvement of the EMMP

Once the repair/maintenance work in the Reserve is completed, the ECO must compile a Completion Statement within one (1) month from end of work and submit the Completion Statement to the DFFE and CapeNature.

## 9 STAKEHOLDER ENGAGEMENT

This EMMP is submitted as a draft report for review and comment by key stakeholders, including mandated Authorities, Organs of State and members of the public for a period no less than 30-days extending from **Friday, 27 February – Monday, 30 March 2026**.

- Newspaper advert has been placed in *Oudtshoorn Courant* and *Friends of Prins Albert Newspaper* calling for I&APs to participate and comment on the document;
- Site Notices have been put up at the Gamkaberg Nature Reserve office and their main entrance gate;
- Electronic copy of the document is available and can be downloaded from [www.cape-eaprac.co.za](http://www.cape-eaprac.co.za) (listed under 'Active Projects') and a hard copy is available at the Gamkaberg Nature Reserve office;

Following the outcome of the stakeholder engagement process, this draft EMMP will be updated to reflect submissions received and all submissions will be considered and responded to where necessary, in order to capture potential outstanding information / oversights or corrections that may be necessary.

The Final MMP containing the submissions received during the stakeholder engagement process, will be submitted to the Competent Authority for review and decision-making.

All submission must be made, in writing or orally to the addresses below, and must reach us no later than **30 March 2026** in order for such submissions to be considered:

Cape Environmental Assessment Practitioners (Pty) Ltd

c/o Louise-Mari van Zyl (Registered EAP, Reg Nu 2019/1444)

Email: [louise@cape-eaprac.co.za](mailto:louise@cape-eaprac.co.za)

Tel: 044-8740365 (verbal communication / comments will be captured)

---

## 10 REFERENCES

- Brown, C. & Magoba, R. (eds.) 2009. Rivers and Wetlands of Cape Town: Caring for Our Rich Aquatic Heritage. Water Research Commission (WRC). Pretoria. (WRC Report No. K5/1691).
- Cape Farm Mapper. 2025. Cape Farm Mapper Version 3.4.1. [Online]. Available from: <https://gis.elsenburg.com/apps/cfm/> CapeNature. 2021.
- Gamkaberg Nature Reserve & World Heritage Site: Protected Area Management Plan 2018 – 2028. Internal Report, CapeNature. Cape Town.
- International Union for Conservation of Nature and Natural Resources (IUCN). 2025. The IUCN Red List of Threatened Species. Version 2025-2. [Online]. Available from: <https://www.iucnredlist.org/> International Union for Conservation of Nature and Natural Resources (IUCN). 2025.
- Cape Floral Region Protected Areas. [Online]. Available from: <https://worldheritageoutlook.iucn.org/exploresites/cape-floral-region-protected-areas>.
- Red List of South African Plants. [Online]. Available from: <https://redlist.sanbi.org/index.php>. Western Cape Government (WCG). 2024.
- Road Network Information System (RNIS). [Online]. Available from: Road Network Information System ([westerncaperoadsinfrastructure.org.za](http://westerncaperoadsinfrastructure.org.za)) Western Cape Government: Department of Environmental Affairs and Development Planning. 2024. Adoption of a Maintenance Management Plan: Request for the adoption of a Maintenance Management Plan in terms of the National Environmental Management Act, 1998 (Act No. 107 of 1998) (“NEMA”) and the Environmental Impact Assessment (“EIA”) Regulations, 2014. April 2024.
- V3 Consulting Engineers. 30 July 2025. Gamkaberg Management Roads Conditional Assessment – Stormwater Damage.
- Western Cape Government: Department of Transport and Public Works. 2021. Maintenance Methods Manual. Roads Branch: Road Departmental Operations, Version 1, Edition 1. 31 May 2021.