

DOORNHOEK PV (PTY) LTD

**TRAFFIC IMPACT ASSESSMENT FOR THE PROPOSED
DOORNHOEK 1 PV FACILITY AS PART OF THE
DOORNHOEK PHOTOVOLTAIC CLUSTER NEAR
KLERKSDORP, NORTH WEST PROVINCE**

34503.01C-REP-001-01

TRAFFIC IMPACT ASSESSMENT

APRIL 2022

PREPARED FOR:

DOORNHOEK PV (PTY) LTD
101 BLOCK A, WEST QUAY BUILDING
7 WEST QUAY ROAD, WATERFRONT
CAPE TOWN
8000

PREPARED BY:



**BVi CONSULTING ENGINEERS WESTERN
CAPE (PTY) LTD**
BLOCK B2, EDISON SQUARE
C/O EDISON WAY AND CENTURY AVENUE
CENTURY CITY
7441

EXECUTIVE SUMMARY

BVi Consulting Engineers Western Cape (Pty) Ltd was appointed by *Doornhoek PV (Pty) Ltd* to conduct a Traffic and Transportation Assessment for the proposed development of the *Doornhoek Solar PV Cluster* on Portion 18 of the Farm Doornhoek No. 372-IP near Klerksdorp, in the North West Province. This proposed cluster is made up of two adjacent photovoltaic (PV) facilities of 115 MW and 50 MW per facility respectively. This specialist study forms part of the requirements for the Draft Basic Assessment Report, and assesses the *Doornhoek 1 PV Facility* (115 MW plant), the northern facility of the cluster.

For the traffic assessment, regional and local transport routes were investigated:

- For regional routes, haulage routes from various ports of entry (Durban Harbour and Saldanha Bay Harbour) were investigated. A regional route from Johannesburg has also been assessed and presented for the haulage of major electrical components.
- For the assessment of local routes, routes close to the site were assessed for impact of local trips on the local network.
- The existing traffic volumes on the transportation routes were sourced and used to calculate the current background traffic, the expected background traffic during construction and, thereby, the Level of Service. The number of trips generated from the construction period were estimated and the impact of these additional trips on the regional and local transport routes were also investigated.

An additional up to 50 MW PV facility (*Doornhoek 2 PV Facility*) is concurrently being considered on the same property and is being assessed through a separate Basic Assessment (BA) process. The cumulative impact of the concurrent development of these two facilities was assessed in terms of traffic.

The following conclusions were drawn from the study:



- The major traffic impact occurs during the construction phase of the project. The impact of the construction trip generation, on the predicted traffic volumes on the local and the regional transportation routes are expected to be low. No mitigation measures for these routes will be necessary.
- The photovoltaic (PV) components will be delivered to site from two possible ports, either from Saldanha Bay Harbour over a distance of 1 340 km or from Durban Harbour over a distance of 665 km. The regional routes indicated in the analysis would need to be confirmed by freight carriers as suitable for the sensitive normal loads. The final decision on the selected route would be based on a combination of cost, distance and road condition at the time of transport.
- Transformer and substation components will be transported via abnormal loads. An abnormal load will necessitate an application for a permit. Only 1-2 abnormal load trips per site is expected for *Doornhoek 1 PV Facility*. Abnormal load transportation is therefore considered to be isolated and would have a negligible impact on traffic over the construction phase of the project.

- In terms of impact on roads infrastructure:
 - It is proposed that the access roads in close proximity to the site be investigated for rehabilitation prior to construction and be maintained during construction in order to mitigate against the possibility of damaged goods due to poor road infrastructure.
 - The site access point will likely need to be formalised, as a requirement as part of the wayleave approval of the local and provincial roads authorities.
 - Adequate traffic accommodation signage must be erected and maintained on either side of the access throughout the construction period of the project.
 - The construction and provision of internal roads that cross the Eskom servitude need to be according to Eskom wayleave requirements.
- In terms of impact on traffic:
 - The regional construction trips will be insignificant when compared to the Average Daily Traffic (ADT) and will not affect the existing Level of Service (LOS). Mitigation measures, such as staggered trips and reduced peak time travel are proposed if needed.
- In terms of cumulative impact:
 - The concurrent construction of *Doornhoek 1 PV Facility* and *Doornhoek 2 PV Facility* is considered to have a low impact. Mitigation measures that may be considered include the staggering of trips at the site and the implementation of a roads maintenance programme.
 - The unlikely concurrent construction of four other solar farms in a 30 km radius of the site has also been considered to be low.

The development of the *Doornhoek 1 PV Facility* on Portion 18 of the Farm Doornhoek No. 372-IP near Klerksdorp in the North West Province can therefore be supported from a traffic engineering perspective.

ISSUE AND REVISION RECORD

QUALITY APPROVAL

	CAPACITY	NAME	SIGNATURE	DATE
By author	Engineer	Lee-Ann Petersen Pr Eng: 20180198		26/04/2022
Checked by	Professional Engineering Technologist	Jacques Nel Pr Tech Eng: 200770131	pp 	26/04/2022
Approved by Design Centre Leader	Director	Dirk van der Merwe Pr Eng: 20120186		26/04/2022

This report has been prepared in accordance with BVi Consulting Engineers Quality Management System. BVi Consulting Engineers is ISO 9001: 2015 registered and certified by NQA Africa.



REVISION RECORD

REVISION NUMBER	OBJECTIVE	CHANGE	DATE
0	Issue to Client for review	None	19/04/2022
1	Address Client feedback	Minor details from pdf mark-up	26/04/2022

TABLE OF CONTENTS

EXECUTIVE SUMMARY	ii
ISSUE AND REVISION RECORD.....	iv
CHAPTER 1 INTRODUCTION.....	1
1.1 TERMS OF REFERENCE.....	1
1.2 OBJECTIVES	1
1.3 APPROACH AND METHODOLOGY	1
1.4 ASSUMPTIONS AND LIMITATIONS.....	2
1.5 REFERENCE DOCUMENTATION	2
CHAPTER 2 PROJECT PARTICULARS.....	3
2.1 PROJECT DESCRIPTION AND SITE LOCATION	3
2.2 EXISTING ROAD NETWORK	4
2.3 PROPOSED SITE LAYOUT	5
2.4 PROPOSED SITE ACCESS ROAD AND INTERNAL ROADS	5
CHAPTER 3 TRANSPORTATION ROUTES.....	7
3.1 OVERVIEW	7
3.2 LEGISLATION AND PERMIT REQUIREMENTS	7
3.3 HAULAGE FROM PORTS OF ENTRY	9
3.4 HAULAGE OF TRANSFORMER AND SUBSTATION COMPONENTS.....	12
3.5 HAULAGE OF OTHER PLANT, CONSTRUCTION MATERIAL AND EQUIPMENT.....	13
3.6 TRANSPORT OF CONSTRUCTION PERSONNEL	13
3.7 ROUTE CLEARANCE.....	13
3.8 SUMMARY	13
CHAPTER 4 BACKGROUND TRAFFIC VOLUMES.....	15
4.1 OVERVIEW	15
4.2 REGIONAL TRAFFIC	15
4.3 LOCAL TRAFFIC.....	16
4.4 CAPACITY ANALYSIS.....	17
CHAPTER 5 TRIP GENERATION.....	18
5.1 OVERVIEW	18
5.2 CONSTRUCTION PHASE.....	18
5.3 OPERATIONAL PHASE.....	19
5.4 DECOMMISSIONING PHASE	19
CHAPTER 6 TRAFFIC IMPACT ASSESSMENT.....	20
6.1 OVERVIEW	20
6.2 ASSESSMENT OF IMPACTS ON REGIONAL TRANSPORTATION ROUTES.....	20

6.3	ASSESSMENT OF IMPACTS ON LOCAL TRAFFIC.....	20
CHAPTER 7 IMPACT ASSESSMENT SUMMARY		22
7.1	OVERVIEW	22
7.2	IMPACT ASSESSMENT – CONSTRUCTION PHASE REGIONAL TRAFFIC	22
7.3	IMPACT ASSESSMENT – CONSTRUCTION PHASE LOCAL TRAFFIC.....	23
7.4	IMPACT ASSESSMENT – SITE ROADS INFRASTRUCTURE	24
7.5	IMPACT ASSESSMENT – OPERATIONAL PHASE TRAFFIC.....	25
CHAPTER 8 CUMULATIVE IMPACT ASSESSMENT		26
8.1	OVERVIEW	26
8.2	CUMULATIVE IMPACT – DOORNHOEK PV CLUSTER	26
8.3	CUMULATIVE IMPACT – SOLAR FARM DEVELOPMENT IN 30km RADIUS	27
CHAPTER 9 SUMMARY AND CONCLUSION		29
9.1	SUMMARY	29
9.2	CONCLUSIONS.....	30
APPENDIX A BACKGROUND TRAFFIC VOLUMES.....		A
APPENDIX B TYPICAL ACCESS GEOMETRY		B
APPENDIX C ASSESSMENT METHODOLOGY.....		C

LIST OF TABLES

<i>Table 3.1: Permits and consent requirements</i>	<i>9</i>
<i>Table 4.1: Traffic recording stations (Port of Durban route)</i>	<i>15</i>
<i>Table 4.2: Traffic recording stations (Port of Saldanha route).....</i>	<i>16</i>
<i>Table 4.3: Traffic recording stations near Klerksdorp</i>	<i>16</i>
<i>Table 4.4: Capacity analysis (background traffic)</i>	<i>17</i>
<i>Table 5.1: Trip generation (construction phase).....</i>	<i>19</i>
<i>Table 6.1: Traffic impact on N12 and R30 (commuter trips)</i>	<i>21</i>
<i>Table 8.1: Additional solar power projects (within 30 km radius from study area).....</i>	<i>27</i>

LIST OF FIGURES

<i>Figure 2.1: Locality of the Doornhoek PV Cluster near the town of Klerksdorp</i>	<i>3</i>
<i>Figure 2.2: Doornhoek 1 and 2 PV Facilities on Portion 18 of Farm Doornhoek No. 372-IP</i>	<i>4</i>
<i>Figure 2.3: Doornhoek 1 PV Facility and site access road.....</i>	<i>6</i>
<i>Figure 3.1: Transportation route (Port of Durban to Doornhoek PV Facility)</i>	<i>10</i>
<i>Figure 3.2: Transportation route (Port of Saldanha to Doornhoek PV Facility).....</i>	<i>11</i>
<i>Figure 3.3: Transportation route (Johannesburg to Doornhoek PV Facility)</i>	<i>12</i>

CHAPTER 1 INTRODUCTION

1.1 TERMS OF REFERENCE

BVi Consulting Engineers Western Cape (Pty) Ltd was appointed by *Doornhoek PV (Pty) Ltd* to conduct a traffic and transportation assessment for the proposed development of the *Doornhoek Solar PV Cluster* near Klerksdorp, in the North West Province. This proposed cluster is made up of two adjacent photovoltaic (PV) solar energy facilities (SEFs) of 115 MW and 50 MW per facility respectively. This specialist study forms part of the requirements for the Draft Basic Assessment Report and assesses the *Doornhoek 1 PV Facility* (115 MW plant).

1.2 OBJECTIVES

The objectives of this specialist traffic and transportation study are as follows:

- To identify the most optimal shipping port(s) and assess feasible transport routes, route lengths and potential constraints for facility components;
- To determine the potential indirect, direct and cumulative risks/ impacts to receptors from a traffic and transportation perspective for this project;
- To propose mitigation measures for identified significant risks/ impacts and enhance positive risk/ impacts of the project; and
- To ensure that the project operations comply with relevant social and environmental standards, policies, laws and regulations in terms of traffic and transportation.

1.3 APPROACH AND METHODOLOGY

The traffic and transportation study deals with the traffic impact on the surrounding road network during three distinct phases: *construction*, *operational* and *decommissioning*. The study considered and assessed the following:

- Site layout, access points and internal roads assessment:
 - Description of the surrounding road network;
 - Description of site layout;
 - Assessment of proposed access points; and
 - Assessment of proposed internal roads.
- Traffic and transportation assessment:
 - Estimation of trip generation;
 - Discussion of potential traffic impacts;
 - Assessment of possible transportation routes; and
 - Assessment of construction and operational (maintenance) vehicle trips.

1.4 ASSUMPTIONS AND LIMITATIONS

The following assumptions and limitations apply to the traffic and transportation study:

- This study is based on the project information provided by the environmental consultants and project managers for the applicant, *Doornhoek PV (Pty) Ltd*;
- According to Eskom specifications for power transformers, the following dimensional limitations need to be adhered to when transporting the transformers:
 - Height: 5000 mm.
 - Width: 4300 mm and
 - Length: 10 500 mm.
- Imported PV energy facility components would be transported from the most feasible port of entry;
- If any elements are manufactured within South Africa, these would be transported from their respective manufacturing centres, which would be either in the greater Johannesburg, Pinetown/Durban or Cape Town for the transformer, inverter and the support structures;
- Civil construction materials would be sourced from nearby towns where possible;
- All other construction materials, for concrete and wearing course, would be sourced from a local licensed quarry (off-site);
- All transportation trips external to the development site would occur on existing surfaced or gravel roads; and
- Maximum vertical height clearances along the transportation route is 5.2 m for abnormal loads.

1.5 REFERENCE DOCUMENTATION

The following documents/sources were used in compiling this report and reference will be made where necessary:

- *Highway Capacity Manual (HCM) 6th Edition*, published by *Transportation Research Board*, October 2016.
- *TRH 11 – Dimensional and Mass Limitations and Other Requirements for Abnormal Load Vehicles*, published by Department of Transport (DoT), August 2009.
- *TMH 17, Volume 1 - South African Trip Data Manual*, published by the *Committee of Transport Officials (COTO)*, September 2012.
- *TRH 17 – Geometric Design of Rural Roads*, published by the *Department of Transport (DoT)*, 1988.

CHAPTER 2 PROJECT PARTICULARS

2.1 PROJECT DESCRIPTION AND SITE LOCATION

The Applicant, *Doornhoek PV (Pty) Ltd*, is proposing the construction of a photovoltaic (PV) solar energy facility (known as the *Doornhoek 1 PV Facility*) located on a site approximately 11 km north of Klerksdorp in the North West Province. The solar PV facility will comprise several arrays of PV panels and associated infrastructure and will have a contracted capacity of up to 115 MW. The development area is situated within the *City of Matlosana Local Municipality* within the *Dr Kenneth Kaunda District Municipality*.

The site for this development is located off a local district road to the east of the development area, which provides multiple farms with access to the greater road network. The access road links to District Road in Klerksdorp, to the south of the site. The nearest regional and national routes are the R30 and the N12 respectively, which are the main routes to Klerksdorp. The location of the site is provided in *Figure 2.1* below.

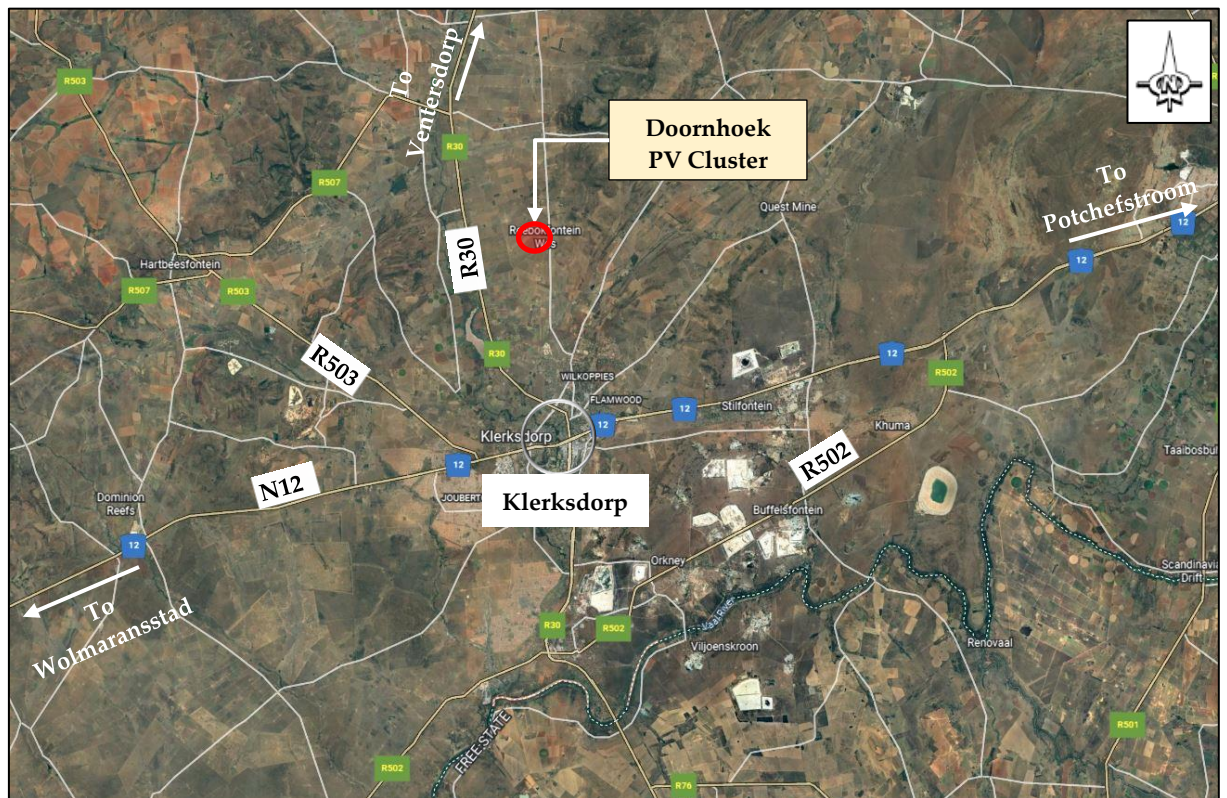

Figure 2.1: Locality of the Doornhoek PV Cluster near the town of Klerksdorp

The proposed *Doornhoek 1 PV Facility* and associated infrastructure will be located on Portion 18 of the Farm Doornhoek No. 372-IP. The project site is located within the Klerksdorp Renewable Energy Development Zones (REDZ), and therefore, a Basic Assessment (BA) process will be undertaken in accordance with GN R114 (as formally gazetted on 16 February 2018).

An additional 50 MW PV facility (*Doornhoek 2 PV Facility*) is concurrently being considered on the same property and is being assessed through a separate Basic Assessment (BA) process. The layout of the cluster is indicated in the figure below.

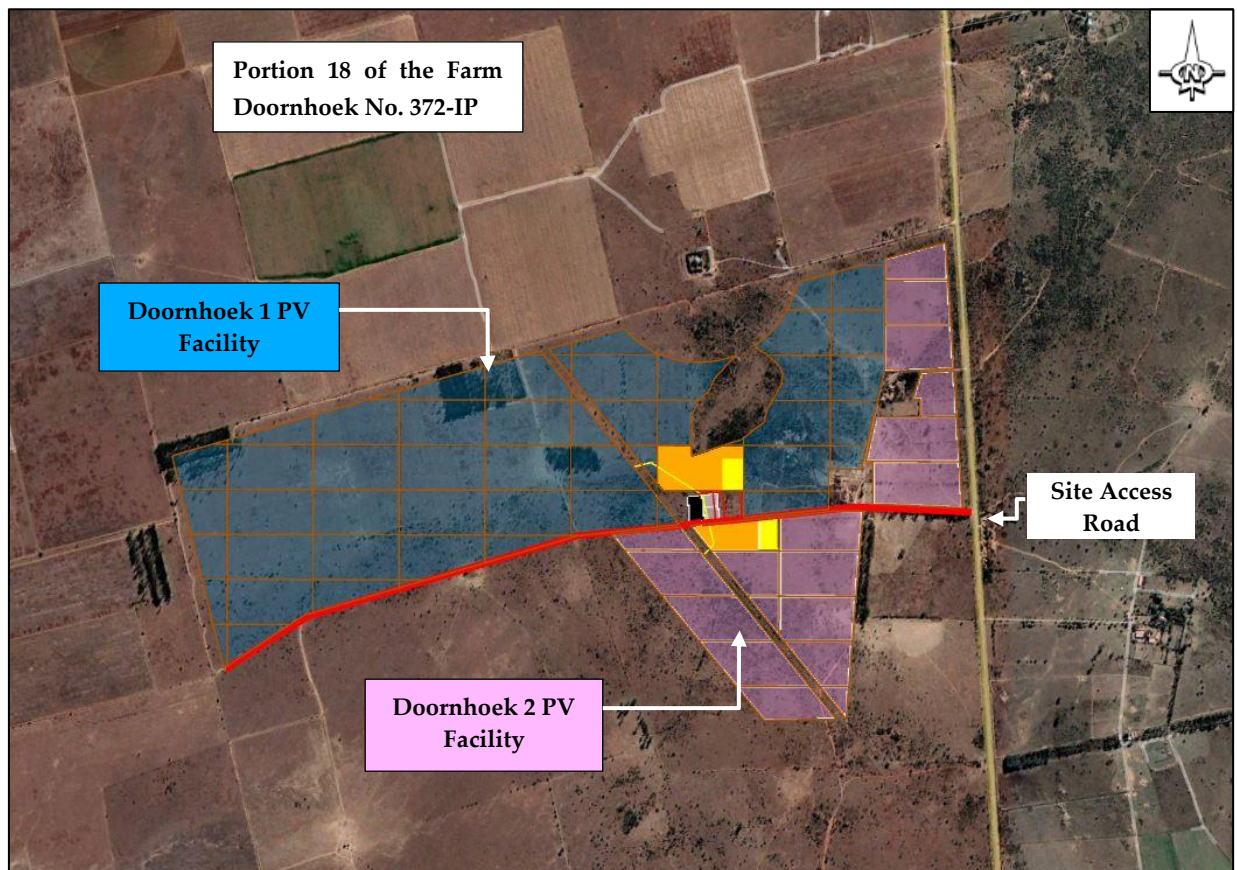

Figure 2.2: Doornhoek 1 and 2 PV Facilities on Portion 18 of Farm Doornhoek No. 372-IP

The proposed *Doornhoek 1 PV Facility* will cover approximately 200 ha and the *Doornhoek 2 PV Facility* will cover approximately 80 ha. This report addresses the traffic impact for the *Doornhoek 1 PV Facility*.

2.2 EXISTING ROAD NETWORK

The site for this development is located off a local district road, which provides multiple farms in the area with access to the greater road network. The road is a two-lane surfaced road. Images from *Google Street View* indicate gravel shoulders.

This access road links to District Road in Klerksdorp, to the south of the site. The major routes in the immediate vicinity of the site are the R30 to the west of the site, N12 to the south of the site and R507 to the north-west of the site.

2.3 PROPOSED SITE LAYOUT

The proposed *Doornhoek 1 PV Facility* will cover approximately 200 ha and will include the following infrastructure:

- PV modules and mounting structures;
- Inverters and transformers;
- Battery Energy Storage System (BESS);
- Site and internal access roads (up to 8m wide);
- Operation and maintenance buildings including a gate house and security building, control centre, offices, warehouses and workshops for storage and maintenance;
- Temporary and permanent laydown area;
- Grid connection infrastructure, including:
 - 33kV cabling between the project components and the facility substation;
 - A 132kV facility substation;
 - A 132kV Eskom switching station; and
 - A Loop-in-Loop-out (LILO) overhead 132kV power line between the Eskom switching station and the existing Watershed–Klerksdorp 1 132kV power line.

The proposed layout is considered as a consideration for the estimation of construction and operational traffic.

2.4 PROPOSED SITE ACCESS ROAD AND INTERNAL ROADS

Access to the site will be via an existing gravel road, which is proposed to be 8 m wide. This access road will need to be investigated for rehabilitation prior to construction to cater for the construction vehicles navigating the road to the laydown areas on site.

This gravel road will need to be suitably maintained. This process would also provide mitigation against the possibility of damaged goods due to poor road infrastructure. Re-gravelling may be necessary as a maintenance measure, from time to time, throughout the operational life of the solar power plant. The site access road is provided in *Figure 2.2* below.

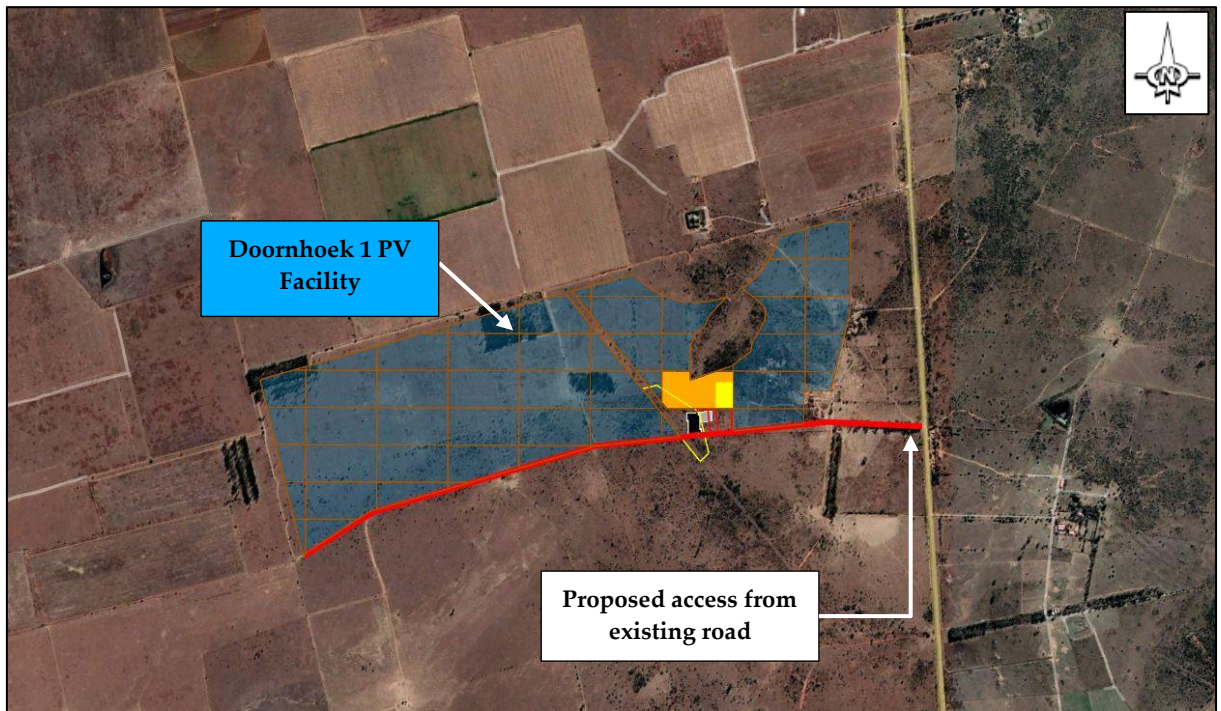

Figure 2.3: Doornhoek 1 PV Facility and site access road

The formalisation and upgrading of the access point to the required standard, as provided in *Appendix B*, will in all probability be a requirement as part of the wayleave approval of *City of Matlosana Local Municipality* and *North West: Department of Public Works and Roads*.

The secondary internal roads are proposed to be 4 m wide (maximum 5 m wide), following the grid layout as indicated in the figure above. It has also been noted that the site layout crosses an Eskom servitude. While no construction of the PV facility occurs within the servitude, the construction and provision of internal roads that cross the servitude need to be according to Eskom wayleave requirements.

In addition, it must be noted that adequate traffic accommodation signage must be erected and maintained on either side of the access throughout the construction phase of the plant, in accordance with the *South African Road Traffic Signs Manual, Vol 2, May 2012*.

CHAPTER 3 TRANSPORTATION ROUTES

3.1 OVERVIEW

Local and regional transportation routes are impacted by the proposed development. Due to the nature of the project, haulage routes from the port of entry for imported PV and related components as well as haulage along local routes for locally sourced construction materials is considered.

The bulk of the haulage would consist of normal heavy vehicles. Abnormal loads are foreseen for the transport of electrical components for the construction of the proposed transformers on the site. The impact of and requirements for abnormal loads are also highlighted.

3.2 LEGISLATION AND PERMIT REQUIREMENTS

The overarching environmental legislation for management of the environment in South Africa, is the *National Environmental Management Act, 1998 (Act 107 of 1998 "NEMA")*. Its foreword states that sustainable development requires the integration of social, economic, and environmental factors in the planning, implementation, and evaluation of environmental decisions to ensure that the development serves present and future generations. Traffic impacts are therefore an important aspect to consider in the decision-making process of developments.

3.2.1 Roads

The relevant legislation associated with the road (infrastructure), transportation and traffic include, inter alia:

- National Water Act (Act 36 of 1998), with regards to all crossings of water courses.
- National Road Traffic Act (Act 93 of 1996).
- National Road Traffic Regulations, 2000.
- Advertising on Road and Ribbon Development Act (Act 21 of 1940).
 - Section 9: Prohibition of erection of structures or construction of other things near intersections of certain roads, and
 - Section 10: Restriction of access to land through fence along certain roads.
- Roads Ordinance Act (Act 19 of 1976).
 - Section 13: Erection of gates across public roads and public paths.
 - Section 17: Erection of structures on or near public roads, and
 - Section 18: Access to and exit from certain public roads and public paths.

3.2.2 Vehicle dimensions

Regulations 221 to 230 of the *National Road Traffic Act* relates to vehicle dimensions. The most important points are summarised below.

- Regulation 221: Defines the legislation requirements regarding the overall length of vehicles. The following lengths shall not be exceeded:
 - Rigid vehicle: 12.5 m.
 - Articulated vehicle and semi-trailer: 18.5 m; and
 - Combination vehicle (interlinks, multiple trailers etc.): 22.0 m
- Regulation 223: Defines the legislation requirements regarding the overall width of vehicles. Vehicles with a gross mass of 12 000 kg or more, shall not exceed 2.6 m.
- Regulation 224: Define the legislation requirements regarding the overall height of a vehicle and transported load, which shall not exceed 4.3 m.
- Regulation 225: Defines the legislation requirements regarding the maximum turning radius and wheelbase, which shall not exceed 13.1 m or 10.0 m (semi-trailer) respectively.

3.2.3 Vehicle loads

Regulations 231 to 249 of the *National Road Traffic Act* relates to vehicle loads. The most important points are summarised below.

- Regulation 240: Defines the legislation requirements regarding the mass load carrying on roads.
- Regulation 241: Defines the legislation requirements regarding the mass load carrying capacity of bridges.

3.2.4 Abnormal load considerations

It is expected that the transformers will be transported with an abnormal load vehicle. Abnormal permits are required for vehicles exceeding the permissible maximum dimensions on road freight transport.

The *National Road Traffic Act (Act 93 of 1996)* and the *National Road Traffic Regulations (2000)* prescribed certain limitations on vehicle dimensions and axle and vehicle masses that a vehicle using a public road must comply with. Where the prescribed limitations are exceeded, these loads are then classified as an abnormal load. Provision for such abnormal vehicles and loads are made in *Section 81 of the National Road Traffic Act*, as substituted by *Section 23 of the National Road Traffic Amendment Act (Act 64 of 2008)*.

The requirements and procedures for transporting of abnormal loads are contained in the following two documents:

- *TRH 11: Dimensional and Mass Limitations and Other Requirements for Abnormal Load Vehicles;* and
- *COTO: Administrative Guidelines for Granting of Exemption Permits for the Conveyance of Abnormal Loads, Revision 2, March 2015.*

The specific permits and consents that may be required from the relevant authorities, for the transportation of abnormal loads, are summarised in *Table 3.1* below.

Table 3.1: Permits and consent requirements

PERMIT/ CONSENT TYPE	RELEVANT AUTHORITY	STRATEGY
Abnormal Load/Vehicle Permit in terms of <i>National Road Traffic Act 93 of 1996, Section 81</i>	<i>Department of Transport: Kwa-Zulu Natal; Department Of Police, Roads And Transport – Free State Provincial Government; Department of Transport, Roads and Community Safety – Provincial Government North West; and Gauteng: Department of Roads</i>	The freight contractor will obtain the necessary road transportation permits.
<i>The South African National Roads Agency Limited and National Roads Act, Act 7 of 1998</i>	<i>South African National Roads Agency SOC Limited (SANRAL)</i>	The freight contractor will obtain the necessary road transportation permits from SANRAL.

It should be noted that embargo days for transportation of abnormal loads generally coincide with public holidays, start and end of school holidays and extended year-end periods. These dates are updated regularly for each provincial roads department.

As discussed further in the report, the number of abnormal load trips per site is considered negligible (1-2 trips per site) and does not have an impact on traffic but the abovementioned permits will still be required. A permit is, however, required for each province that the transportation route traverses.

3.3 HAULAGE FROM PORTS OF ENTRY

The closest port of entry for consideration is the Durban Harbour. An alternative port of entry that has been considered is the Saldanha Bay Harbour. The distance from the Durban Harbour is approximately 665 km and from Saldanha Bay Harbour measures approximately 1 340 km.

3.3.1 Alternative 1: Port of Durban (665 km)



Figure 3.1: Transportation route (Port of Durban to Doornhoek PV Facility)

The route overview shown in *Figure 3.2* (Source: Google Maps) is briefly described below:

- From Durban Harbour, take Langeberg Rd, Bayhead Rd and R102 to Edwin Swales Dr/Solomon Mahlangu Dr/M7 in Sea View. Exit from R102 (9.3 km);
- Follow N3 and N5 to Hospital Rd/R26 in Bethlehem (384 km);
- Take R76 and R30 to your destination in North West (271 km).

It should be noted that this route has tolls.

3.3.2 Alternative 2: Port of Saldanha (1 340 km)

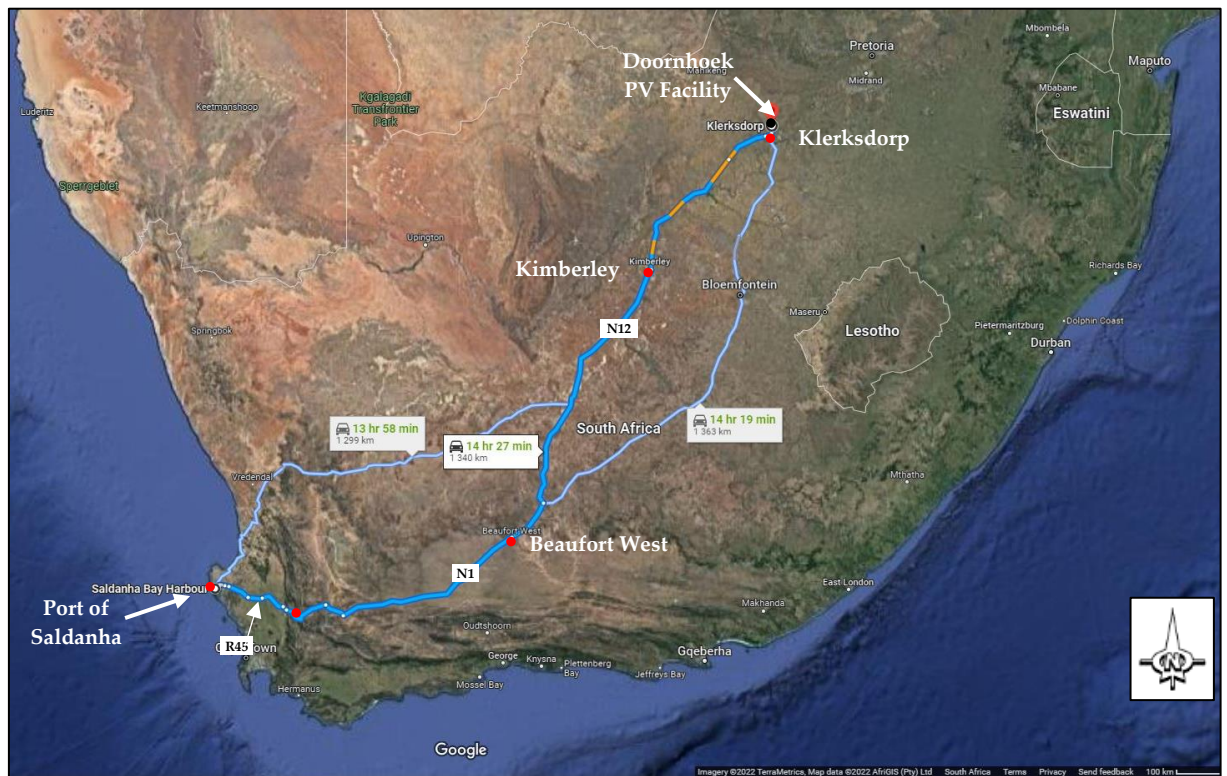

Figure 3.2: Transportation route (Port of Saldanha to Doornhoek PV Facility)

The route overview shown in *Figure 3.1* (Source: Google Maps) is briefly described below:

- From Saldanha Bay Harbour Take R45, R311, Gouda Rd and R46 to N1 in Western Cape (235 km);
- Follow N1 and N12 to Leemhuis St in Freemanville, Klerksdorp (1,089 km);
- Drive to your destination 16 min (15.5 km).

3.3.3 Recommended port of entry

In terms of transport and traffic impact, the recommended port of entry is considered to be Durban Harbour. It is currently the largest harbour in South Africa and is the closest harbour to the site. It is recognised that effort is being made to shift cargo from Durban Harbour to Richards Bay Harbour and East London Harbour. The Durban Harbour is proposed as the preferred harbour along the eastern coast.

Saldanha Bay Harbour is considered a suitable option on the western coast. The route has been analysed and shows routes along national roads, catering for freight transport.

The regional routes indicated in the analysis would need to be confirmed by freight carriers as suitable for the sensitive normal loads and for any abnormal loads. The final decision on the selected route would be based on a combination of cost, distance and road condition at the time of transport.

3.4 HAULAGE OF TRANSFORMER AND SUBSTATION COMPONENTS

Transformer and substation components are envisaged to form part of the regional trips. It is anticipated that these components would be imported and transported from the preferred harbour (Saldanha or Durban Harbour) as abnormal loads. It would very likely be assembled in Johannesburg and transported to the *Doornhoek 1 PV Facility* site, also requiring abnormal load transport. The distance from Johannesburg to *Doornhoek 1 PV Facility* is approximately 185 km, along the N12.

It should be noted that only 1-2 abnormal load trips per site is expected for *Doornhoek 1 PV Facility*. Abnormal load transportation is therefore considered to be isolated and would have a negligible impact on traffic over the construction phase of the project. As indicated in *Section 3.2.4 above*, the abnormal load will still necessitate the application of an abnormal load permit for each province that the route traverses.

The route from Johannesburg to the site traverses the *Gauteng Province* and the *North West Province*. In addition to the ports of entry, abnormal haulage is also expected from Johannesburg. The route is indicated in Figure 3.3.

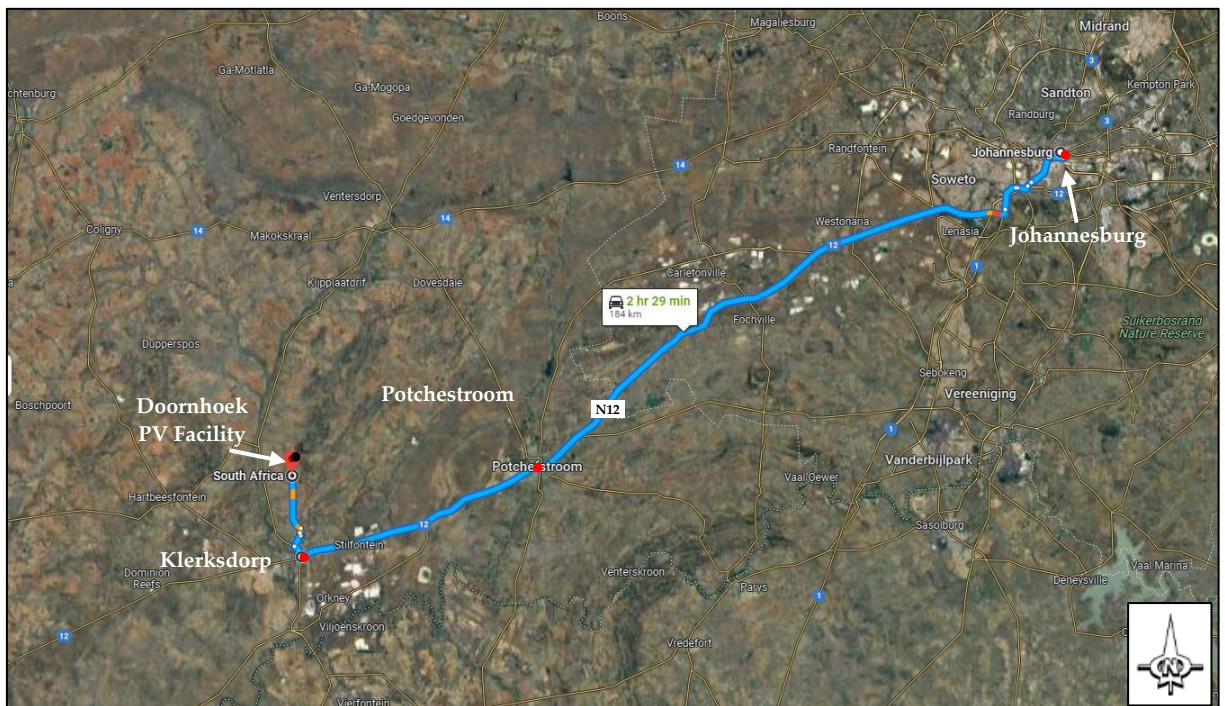

Figure 3.3: Transportation route (Johannesburg to Doornhoek PV Facility)

The route description (*Source: Google Maps*) is as follows:

- Drive onto Francois Oberholzer Freeway/M2 in Village Main, Johannesburg South from Von Wielligh St and Dennis Rd;
- Follow N12 to Chris Hani Rd/Jan Van Riebeeck Rd/R30 in Klerksdorp Central, Klerksdorp. Exit from N12 (166 km);

- Drive to your destination (16.1 km) in the *City of Matlosana*.

This route is also appropriate for haulage of normal heavy loads from Gauteng. It should be noted that this is a general route description highlighting the N12 regional route, as location of suppliers is not yet established.

3.5 HAULAGE OF OTHER PLANT, CONSTRUCTION MATERIAL AND EQUIPMENT

In addition to transporting the specialised equipment, the normal civil engineering construction materials, plant and equipment will need to be transported to the site (e.g. sand, stone, cement, gravel, water, compaction equipment, concrete mixers, etc.). Other components, such as electrical cables, pylons and substation transformers, will also be transported to site during construction. The transport of these items will generally be conducted with normal heavy loads vehicles, except for the transformers as previously discussed.

Cement will be sourced from local manufacturers in nearby towns. All other civil construction materials, needed for concrete and wearing course, will be obtained from a local licensed quarry off-site. These trips can be classified as local trips as vehicles will not be travelling over a very long distance.

3.6 TRANSPORT OF CONSTRUCTION PERSONNEL

It is anticipated that construction personnel and labour would originate from neighbouring towns. These trips can be classified as local trips as vehicles will not be travelling over a very long distance.

3.7 ROUTE CLEARANCE

The vehicles used to transport the photovoltaic equipment are standard container trucks. The transformers will be transported as abnormal loads. At this stage of the project, the routes and areas for clearance cannot be established and should be confirmed with the freight carriers in later stage of the project. However, no new obstacles (e.g. low overhead services, cattle grids, narrow bridges, etc.) are expected for abnormal load haulage as similar projects in close proximity to the proposed development may have previously cleared areas along transport routes.

3.8 SUMMARY

It is anticipated that the solar panel technology and larger electrical components would be imported and arrive via ship at marine ports of entry. Haulage routes from two ports of entry, namely Saldanha Bay Harbour and Durban Harbour, were identified and assessed. The final decision on the selected route would be based on a combination of cost, distance and road condition at the time of transport.

Minimal abnormal load trips for transformers would be required for the project. It is anticipated that this would require haulage from the port of entry to the manufacturing site (possibly Johannesburg) before being hauled to site. These are considered to induce minimal impact on traffic over the course of the construction period but will require the necessary permits for abnormal load transport.

The materials required for site, including the solar panel technology would require transport by normal heavy vehicle loads. As discussed in Section 2.4 above, it is proposed that the access roads in close proximity to the site be investigated for rehabilitation prior to construction and be maintained during construction in order to mitigate against the possibility of damaged goods due to poor road infrastructure.

CHAPTER 4 BACKGROUND TRAFFIC VOLUMES

4.1 OVERVIEW

Background traffic volumes were determined for the study network near the site, as well as along the transportation routes. These traffic volumes were acquired in order to determine what the existing traffic conditions are like in the absence of the proposed solar power plant.

Various traffic recording stations on major roadways, along transportation routes, were identified and are provided in the sub-chapters below. The traffic count data was mainly sourced from temporary counting stations, for which approximately one week of traffic data was recorded. Where available, permanent counting stations provided historic data over multiple years, indicating trends in traffic growth at those locations.

It must be noted that the traffic data was only recorded up until December 2019. The period for traffic assessment was selected as four years as it is estimated that approvals, planning and design phases would take 2-3 years and the construction phase, which would generate the highest number of trips for the project, would occur during year 4. Therefore, the existing traffic volumes for the years 2020 to 2022 for current estimated traffic volumes and to 2026 for the four-year horizon for traffic assessment were predicted as described below.

4.2 REGIONAL TRAFFIC

4.2.1 Alternative 1: Port of Durban to Doornhoek 1 PV Facility

The following traffic recording stations were identified along the Durban route:

Table 4.1: Traffic recording stations (Port of Durban route)

SITE IDENTIFIER	LOCATION	ROUTE	NO. OF LANES	2019 AVERAGE DAILY TRAFFIC (ADT)	2019 AVERAGE DAILY TRUCK TRAFFIC (ADTT) (% OF ADT)
1990 - Estcourt I/C	Southern side of Giants Castle I/C	N3	6	17611	7487 (42.5%)
533 - Bethlehem East	Between Kestell and Bethlehem	N5	2	5020	1393 (27.7%)
875 - Bethlehem	5 km west of Bethlehem	N5	2	4330	1088 (25.1%)

From the table above it can be seen that heavy vehicles contribute between 25% and 43% to the total traffic volumes along the Durban transportation route.

4.2.2 Alternative 2: Port of Saldanha to Doornhoek 1 PV Facility

The following traffic recording stations were identified along the Saldanha route:

Table 4.2: Traffic recording stations (Port of Saldanha route)

SITE IDENTIFIER	LOCATION	ROUTE	NO. OF LANES	2019 AVERAGE DAILY TRAFFIC (ADT)	2019 AVERAGE DAILY TRUCK TRAFFIC (ADTT) (% OF ADT)
1337 - Touwsriver West	2km West of N1 Touwsriver I/S	R46	2	689	194 (28.2%)
5066 - PGWC CeresKaroo	Between R46 & Calvinia	R355	2	328	56 (17.1%)

From the table above it can be seen that heavy vehicles contribute between 17% and 28% to the total traffic volumes along the Saldanha transportation route.

4.3 LOCAL TRAFFIC

The following traffic station data was acquired from SANRAL for the main routes in the region of Klerksdorp. These sites were short-term counts that were recorded in 2019.

Table 4.3: Traffic recording stations near Klerksdorp

SITE IDENTIFIER	LOCATION	ROUTE	NO. OF LANES	2019 AVERAGE DAILY TRAFFIC (ADT)	2019 AVERAGE DAILY TRUCK TRAFFIC (ADTT) (% OF ADT)
19847 - Regina	Between Klerksdorp and Wolmaransstad	N12	4	14809	1361 (9.20%)
19848 - Flamwood SB	Between Klerksdorp and Stilfontein	N12	3	9632	1034 (10.70%)
19849 - Flamwood NB	Between Klerksdorp and Stilfontein	N12	2	9437	1073 (11.40%)
19220 - Lapfontein	Between Ventersdorp and Klerksdorp	R30	2	2833	347 (12.20%)

The surveyed traffic data above has been used to estimate current day 2022 average daily traffic and for the 4-year horizon background daily traffic.

4.4 CAPACITY ANALYSIS

The following capacity analysis considers only the background traffic, without the additional traffic due to the development.

The *TRH 17* document was consulted in order to determine whether the capacities of the above-mentioned roadways would be exceeded within the near future. The capacity analysis results are indicated in Table 4.4 below.

The estimated background traffic for the current year (2022) and for the horizon year (2026) was determined according to the available data. The historic data for the regional traffic was used with a trendline analysis to estimate the background traffic for the current year and horizon year. The local traffic was escalated with 1.0% per annum to estimate the background traffic for the same years. The predicted traffic volumes for the year 2026 is provided in the table below. See *Appendix A* for graphical illustration.

Table 4.4: Capacity analysis (background traffic)

SITE IDENTIFIER	ROUTE	2022 ADT (vpd)	2022 LEVEL OF SERVICE (LOS)	2026 ADT (vpd)	2026 LEVEL OF SERVICE (LOS)
REGIONAL TRAFFIC – DURBAN ROUTE					
1990	N3	17105	B	17105	B
533	N5	5153	C	5208	C
875	N5	4663	C	5045	C
REGIONAL TRAFFIC – SALDANHA ROUTE					
1337	R46	714	A	755	A
5066	R355	329	A	396	A
LOCAL TRAFFIC					
19847	N12	15258	B	15877	B
19848	N12	9924	B*	10327	B*
19849	N12	9723		10118	
19220	R30	2919	C	3037	C

*The northbound and southbound traffic for the two counting stations (19848, 19849) have been evaluated as a combined 4-lane freeway

The section on the N3 (SITE ID 1990) consists of three lanes in each direction. LOS assessed as 4-lane freeway. Trendline indicated negative growth. Zero change in traffic was therefore selected instead of decreased traffic.

From the table above it is concluded that the capacities of the assessed roadways are not degraded or exceeded in terms of average daily traffic volumes due to background traffic within the assessment period.

CHAPTER 5 TRIP GENERATION

5.1 OVERVIEW

The proposed *Doornhoek 1 PV Facility* will generate additional traffic on the surrounding road network in three (3) distinct phases, namely: construction, operational and decommissioning. It must be noted that these three phases will generate traffic consecutively and not simultaneously, and therefore will be considered separately from each other.

5.2 CONSTRUCTION PHASE

Trips generated during the construction phase will primarily comprise of transporting equipment, energy facility components, personnel, construction and other facility materials. These trips will comprise of normal, medium and heavy vehicles.

The following assumptions were made in order to calculate trips generated during the construction phase of the project:

- It is estimated that the construction period will last approximately eighteen (18) months, with twenty-two (22) working days per month. This results in approximately 400 working days over the construction period.
- The *Doornhoek 1 PV Facility* will most likely be constructed from components that will be shipped to South Africa via the Port of Durban. These components will be transported to site via road transport using medium and heavy vehicles.
 - The solar energy facility will generate approximately up to 115 MW electrical power.
 - Approximately 261 000 PV modules of approximately 300 – 550 W each will be delivered to site. Approximately 660 of these 300 – 550 W units can fit into one (1) container (30 units per pallet; 22 pallets per container). This results in approximately 400 container loads in total being delivered to site.
- Other plant, materials and equipment will be sourced from the nearest towns. An average of 200 -300 trips per 7MW is assumed. For this site, this has been assumed to be 40 trips per MW. This results in approximately 4 600 trips over the 18-month construction period.

Another contributor to trips generated during the construction phase will be daily commuters/workers. The following assumptions were made in this regard:

- The construction labour force will be mostly local.
- It is assumed that approximately 350 staff members/workers will be on site.
 - Based on the composition it is assumed that 10% of the staff members will make use of private or company vehicles (cars and LDVs). These staff members will travel from their permanent or temporary residences to site on a daily basis.

- It is assumed that the remainder of the staff members (90%) will be transported to site with 15-seater minibus-taxis. The quantities of these vehicles will fluctuate and will depend on the number of labourers, costs, routes and operating hours.

The table below summarises the estimated total trips that will be generated during the construction phase of the project:

Table 5.1: Trip generation (construction phase)

TRANSPORT TYPE	SITE	PARAMETER	AVERAGE DAILY TRAFFIC	MONTHLY TRAFFIC	TOTAL TRIPS (18mo.)
Normal heavy load (solar panels)	Doornhoek 1	660 panels per container	1	22	400
Normal heavy load (construction materials)	Doornhoek 1	40 trips/MW	12	264	4 600
LDVs and cars (Staff)	Doornhoek 1	350 staff	56	1232	22 400
TOTAL TRIPS FOR CONSTRUCTION PERIOD			69	1 518	27 400

It can be seen from the table above that the construction phase of *Doornhoek 1 PV Facility* will generate approximately **27 400** trips over the eighteen (18) month period.

5.3 OPERATIONAL PHASE

The following assumptions were made with regards to the trip generation during the operational phase of the solar power plant:

- The *Doornhoek 1 PV Facility* will be in operation between twenty (20) and thirty (30) years.
- The solar energy facility will be in operation seven (7) days a week. Therefore, personnel will operate according to shifts.
- The operational team will consist of approximately fifty (50) people:

The traffic impact during the operational phase will therefore be insignificant, as approximately only fifty (50) people will work at the solar power plant.

5.4 DECOMMISSIONING PHASE

The decommissioning phase will start at the end of the *Doornhoek 1 PV Facility* lifetime (20 – 30 years) and will last approximately six (6) months, involving a team of fifty (50) workers. As per the operational phase, the traffic impact will be insignificant.

CHAPTER 6 TRAFFIC IMPACT ASSESSMENT

6.1 OVERVIEW

The expected effects of traffic that would be generated by the proposed Doornhoek 1 PV Facility analysed as follows:

- The background traffic volumes were determined for the study network near the site, as well as along the transportation routes (Refer to *Chapter 4: Background Traffic Volumes*).
- The existing traffic volumes for the years 2020 to 2026 were predicted and were based on trendline analyses or annual escalation as indicated.
- Construction phase traffic (site-generated trips) were estimated for the proposed solar power plant.
- The construction phase traffic is then added to the 2026 background traffic volumes to determine the total traffic conditions with the solar power plant completed.

The sub-chapters below provide the impact the development of the solar power plant will have on the transportation routes and local traffic respectively.

6.2 ASSESSMENT OF IMPACTS ON REGIONAL TRANSPORTATION ROUTES

The trips generated by this development were evaluated in relation to the quantum of trips needed to change the Level of Service (LOS) on a portion of the rural highway and the ultimate capacity of two-lane highways.

As seen in Chapter 5, the traffic impact of the delivery and construction trips on the Saldanha and Durban routes are minimal, with average additional traffic of 1 trip per day from the ports of entry over the duration of the project, and 12 trips per day for normal heavy vehicles for construction materials.

These construction trips will be insignificant when compared to the Average Daily Traffic (ADT) and will not affect the existing Level of Service (LOS). It can therefore be concluded that, in terms of estimated traffic volumes, no mitigation measures will be necessary.

6.3 ASSESSMENT OF IMPACTS ON LOCAL TRAFFIC

The capacity of a two-lane highway is 3200 vehicles per hour (vph), under ideal conditions, *HCM 6th Edition Chapter 15: Two Lane Highways*. The ideal conditions referred to is the absence of any restrictive geometry, traffic, or environmental factors.

From traffic count data and Level of Service calculations, the N12 and R30 around Klerksdorp have sufficient spare capacity to accommodate the additional traffic due to the development. The table below indicate the effect of the commuter trips on the N12 and R30.

Table 6.1: Traffic impact on N12 and R30 (commuter trips)

SITE ID	ROUTE	2026 EST. ADT ON ROUTE (vpd)	CONSTRUCTION TRIPS (vpd)	TOTAL TRIPS (vpd)	LOS
19847	N12	15 887	69	15 956	B
19848	N12	10 327	69	10 396	B
19849	N12	10 118	69	10 187	B
19220	R30	3 037	69	3 106	C

It can be concluded from the table above that the estimated additional traffic generated by the development, when travelling to/from the *Doornhoek 1 PV Facility*, can be accommodated on the existing road network. Mitigation measures would not be required to due to the increased traffic.

From a traffic point of view, it was found that the total daily construction traffic will be low and will not significantly influence the surrounding communities.

CHAPTER 7 IMPACT ASSESSMENT SUMMARY

7.1 OVERVIEW

The impact of the proposed development has been assessed in terms of traffic as shown below. For the purpose of the environmental impact reporting requirements of the 2014 EIA Regulations, the traffic impact of the proposed development is presented in terms of the assessment methodology described in *Appendix C* of this report.

7.2 IMPACT ASSESSMENT – CONSTRUCTION PHASE REGIONAL TRAFFIC

In terms of traffic and transport, the impact that the proposed development has is as follows:

<i>Nature:</i> <u>Increased traffic on regional haulage routes:</u>		
The haulage routes for light and heavy vehicles include regional routes that would be impacted by the construction of the development. The delivery of imported construction materials to site would likely originate from Johannesburg and Durban Harbour, as discussed in the preceding chapter, slightly increasing the average daily traffic of the routes used over the construction period.		
	Without mitigation	With mitigation
<i>Extent</i>	Regional (3)	Regional (3)
<i>Duration</i>	Short-term (2)	Short-term (2)
<i>Magnitude</i>	Small (1)	Small (1)
<i>Probability</i>	Probable (3)	Probable (3)
<i>Significance</i>	Low (18)	Low (18)
<i>Status (positive or negative)</i>	Neutral	Neutral
<i>Reversibility</i>	Completely	Completely
<i>Irreplaceable loss of resources?</i>	No loss	No loss
<i>Can impacts be mitigated?</i>	Yes, to a limited extent. The benefit of mitigation would not be viable for the project.	
<i>Mitigation:</i> The impact of the increased traffic on regional routes can be mitigated by staggering trips and scheduling so that peak hour traffic in local towns is not impacted by construction traffic.		
<i>Residual Impacts:</i> The magnitude of the increased traffic on regional routes is too small to solely attribute any negative impact on routes to the development's construction traffic.		

7.3 IMPACT ASSESSMENT – CONSTRUCTION PHASE LOCAL TRAFFIC

Nature: <u>Increased traffic on local routes:</u>		
The increased traffic on the local routes may add to local congestion in the town. It should be noted that this would only be noticeable if construction traffic passes through the local town during peak periods. In general, only approximately 15% of daily traffic may be attributed to peak hour volumes.		
	Without mitigation	With mitigation
Extent	Local (2)	Local (2)
Duration	Short-term (2)	Short-term (2)
Magnitude	Small (1)	Small (1)
Probability	Probable (3)	Probable (3)
Significance	Low (15)	Low (15)
Status (positive or negative)	Neutral	Neutral
Reversibility	Completely	Completely
Irreplaceable loss of resources?	No loss	No loss
Can impacts be mitigated?	Yes, the increased traffic can be mitigated to a limited extent. Mitigation in terms of road condition need to be addressed as part of the maintenance during construction.	
Mitigation: The impact of the increased traffic on local routes can be mitigated by staggering trips and scheduling so that peak hour traffic in local towns is not impacted by construction traffic.		
Residual Impacts: The magnitude of the increased traffic on local routes are minimal. Local traffic will mainly be impacted during peak hours.		

7.4 IMPACT ASSESSMENT – SITE ROADS INFRASTRUCTURE

Nature: <u>Construction and maintenance of gravel roads in vicinity of the site:</u>		
<p>The construction traffic accessing the site would be traveling along roads that are proposed to be unsurfaced for the development. The movement of heavy vehicles along the gravel roads, especially close to the boundaries of the site, may cause excessive dust in the area. Deterioration of gravel roads may also occur after wet seasons, leading to poor road conditions for transportation on site.</p>		
	Without mitigation	With mitigation
Extent	Local (1)	Local (1)
Duration	Short-term (2)	Short-term (2)
Magnitude	Small (1)	Small (1)
Probability	Probable (3)	Probable (3)
Significance	Low (12)	Low (12)
Status (positive or negative)	Neutral	Neutral
Reversibility	Completely	Completely
Irreplaceable loss of resources?	No loss	No loss
Can impacts be mitigated?	Yes.	
Mitigation:		
<p>Maintenance to lower order roads can be incorporated into the schedule, especially the maintenance of the road accessing the site. The site access road would require construction at the start of the construction project, in order to safely transport the sensitive cargo through the site. A gravel roads maintenance programme for the gravel roads on site is recommended.</p>		
Residual Impacts:		
<p>A gravel roads maintenance programme will need to be developed and adhered to for the construction as well as operational phase of the development. Maintenance of the roads on the site need to be enforced to ensure deterioration is controlled.</p>		

7.5 IMPACT ASSESSMENT – OPERATIONAL PHASE TRAFFIC

Nature: <u>Increased traffic during operational phase:</u>		
The current traffic will increase slightly due to the employees on site during the operational phase. The traffic generated during this phase will be minimal and will not have any impact on the surrounding road network.		
	Without mitigation	With mitigation
Extent	Local (1)	Local (1)
Duration	Long-term (4)	Long-term (4)
Magnitude	Small (1)	Small (1)
Probability	Probable (3)	Probable (3)
Significance	Low (18)	Low (18)
Status (positive or negative)	Neutral	Neutral
Reversibility	Completely	Completely
Irreplaceable loss of resources?	No loss	No loss
Can impacts be mitigated?	Yes, to a limited extent	
Mitigation:		
The impact of the increased traffic during the operational phase is negligible due to the expected number of employees. The shift work provides a mitigation and reduces the expected number of employees, especially during peak hours.		
Residual Impacts:		
The magnitude of the increased traffic is relatively small and is not likely to change during the operational phase of the development. These trips will become part of the network trips due to the development.		

CHAPTER 8 CUMULATIVE IMPACT ASSESSMENT

8.1 OVERVIEW

The cumulative impact of the proposed development has been assessed in two phases. It has been assessed, firstly, in terms of the cumulative impact of the implementation of the *Doornhoek 1 PV Facility* together with the neighbouring *Doornhoek 2 PV Facility* and then, secondly, in terms of the cumulative impact of the *Doornhoek PV Cluster* together with similar solar farm developments within a 30 km radius.

8.2 CUMULATIVE IMPACT – DOORNHOEK PV CLUSTER

Doornhoek 1 PV Facility and *Doornhoek 2 PV facility* are two proposed developments that are being planned concurrently and are adjacent to each other. The concurrent construction of these facilities would increase the trip generation to the cumulative trip generation for the combined sites, as all trips would require the use of the same access road.

<i>Nature: Increased traffic on local routes:</i>		
<p>The increased traffic on the local routes may add to local congestion in the town. The estimated total average daily traffic generation for <i>Doornhoek 1</i> is 69 vehicles per day and 65 vehicles per day for <i>Doornhoek 2</i>. The resulting cumulative 134 vehicles indicates that the average daily local traffic would need to be accommodated at the site access and public road adjacent to the site. As per the individual impact assessment, in general, only approximately 15% of daily traffic could be attributed to peak hour volumes.</p> <p>The increased heavy traffic on local routes may also contribute to the deterioration of lower order roads over time.</p>		
	Without mitigation	With mitigation
<i>Extent</i>	Local (2)	Local (2)
<i>Duration</i>	Short-term (2)	Short-term (2)
<i>Magnitude</i>	Small (1)	Small (1)
<i>Probability</i>	Probable (3)	Probable (3)
<i>Significance</i>	Low (15)	Low (15)
<i>Status (positive or negative)</i>	Neutral	Neutral
<i>Reversibility</i>	Completely	Completely
<i>Irreplaceable loss of resources?</i>	No loss	No loss
<i>Can impacts be mitigated?</i>	<p>Yes, the increased traffic can be mitigated to a limited extent.</p> <p>Mitigation in terms of road condition need to be addressed as part of the maintenance during construction.</p>	
<i>Mitigation:</i>		

The impact of the increased traffic on local routes can be mitigated by staggering trips and scheduling so that peak hour traffic in local towns is not impacted by construction traffic.

Maintenance to lower order roads can be incorporated into the schedule, especially the maintenance of the road accessing the site. The site access road would require construction at the start of the construction project, in order to safely transport the sensitive cargo through the site.

Residual Impacts:

The magnitude of the increased traffic on local routes are minimal. Local traffic will mainly be impacted during peak hours.

Maintenance of the roads on the site need to be enforced to ensure deterioration is controlled.

8.3 CUMULATIVE IMPACT – SOLAR FARM DEVELOPMENT IN 30km RADIUS

Table 8.1 below provides a summary of other renewable energy projects that may be constructed during the same period as the *Doornhoek 1 PV Facility*. While this is unlikely, all these projects are included in the cumulative trip generation and subsequently the cumulative impact assessment.

The expected regional trip generation presented below has been based on the proportional number of PV panels requiring transport from a port of entry, in comparison to the design MW capacity of Doornhoek.

Table 8.1: Additional solar power projects (within 30 km radius from study area)

NO.	PROJECT NAME	DISTANCE FROM STUDY AREA (km)	CAPACITY (MW)	EXPECTED TOTAL REGIONAL TRIPS
1	Doornhoek 2 PV	-	50 MW	180
2	Buffels Solar 2	26 km	100 MW	350
3	Buffels Solar 1	25 km	75 MW	260
4	Witkop Solar PV II	27 km	61 MW	220
5	Kabi Vaalkop PV	23 km	75 MW	260
TOTAL REGIONAL TRIPS OVER CONSTRUCTION PERIOD				1 270

It can be assumed that only the regional routes could be assessed cumulatively, as the local routes would differ for each site’s primary study area. The above total trips results in an additional 3 daily trips over a 400-day construction period. This is deemed negligible and would not have an impact on regional routes during a scenario of concurrent construction.

The cumulative impact assessment on the regional routes, assessed according to the assessment methodology is presented as follows:

<i>Nature: Increased traffic on regional haulage routes:</i>		
<p>The haulage routes for heavy vehicles for the shipment of solar panels and major components include regional routes that would be impacted by the simultaneous construction of similar projects within 30 km of the development. This cumulative scenario is expected to slightly increase the average daily traffic of the routes used over the construction period.</p>		
	Without mitigation	With mitigation
<i>Extent</i>	Regional (3)	Regional (3)
<i>Duration</i>	Short-term (2)	Short-term (2)
<i>Magnitude</i>	Small (0)	Small (0)
<i>Probability</i>	Very improbable (1)	Very improbable (1)
<i>Significance</i>	Low (5)	Low (5)
<i>Status (positive or negative)</i>	Neutral	Neutral
<i>Reversibility</i>	Completely	Completely
<i>Irreplaceable loss of resources?</i>	No loss	No loss
<i>Can impacts be mitigated?</i>	Yes, to a limited extent.	
<i>Mitigation:</i>		
<p>The cumulative impact would not require mitigation, as the regional routes would still operate at an acceptable level of service. Should mitigation be required, the staggering of trips would be encouraged to avoid platooning of heavy vehicles along regional routes. This would, however, require a degree of co-ordination between the various developments.</p>		
<i>Residual Impacts:</i>		
<p>The magnitude of the increased traffic on regional routes is too small to solely attribute any negative impact on routes to the development's construction traffic. The duration of the impact is also short-term and is reversed after the construction period.</p>		

CHAPTER 9 SUMMARY AND CONCLUSION

9.1 SUMMARY

The proposed *Doornhoek 1 PV Facility* is located on a site approximately 11 km north of Klerksdorp in the North West Province. It will comprise several arrays of PV panels and associated infrastructure and will have a contracted capacity of up to 115 MW. The proposed *Doornhoek 1 PV Facility* will be located on Portion 18 of the Farm Doornhoek No. 372-IP and is proposed to cover approximately 200 ha. The infrastructure will include the PV grid with inverters and transformers, BESS, operations and maintenance buildings, internal site roads and electrical grid connection infrastructure.

The site for this development is located off a two-lane surfaced local district road, which provides multiple farms in the area with access to the greater road network. This access road links to District Road in Klerksdorp, to the south of the site. The major routes in the immediate vicinity of the site are the R30 to the west of the site, N12 to the south of the site, which have been used in the traffic impact evaluation.

For the traffic assessment, regional and local transport routes were investigated:

- For regional routes, haulage routes from various ports of entry (Durban Harbour and Saldanha Bay Harbour) were investigated. The regional routes were mainly national routes, with the N3 and N5 considered from Durban Harbour and R45 and R46 considered from Saldanha Bay Harbour. A regional route from Johannesburg has also been assessed and presented for the haulage of major electrical components.
- For the assessment of local routes, routes close to the site were assessed for impact of local trips on the local network.
- The existing traffic volumes on the transportation routes were sourced and used to calculate the current background traffic, the expected background traffic during construction and, thereby, the Level of Service. The number of trips generated from the construction period were estimated and the impact of these additional trips on the regional and local transport routes were also investigated.

An additional up to 50 MW PV facility (*Doornhoek 2 PV Facility*) is concurrently being considered on the same property and is being assessed through a separate Basic Assessment (BA) process. The cumulative impact of the concurrent development of these two facilities was assessed in terms of traffic.

Also, as part of the cumulative impact assessment, similar solar farm projects within a radius of 30 km were also assessed and the impact assessment reported in terms of the assessment methodology required.

9.2 CONCLUSIONS

The following conclusions were drawn from the study:

- The major traffic impact occurs during the construction phase of the project. The impact of the construction trip generation, on the predicted 2026 (estimated time of construction) traffic volumes on the local and the regional transportation routes are expected to be low. No mitigation measures for these routes will be necessary.
- The photovoltaic (PV) components will be delivered to site from two possible ports, either from Saldanha Bay Harbour over a distance of 1 340 km or from Durban Harbour over a distance of 665 km. The regional routes indicated in the analysis would need to be confirmed by freight carriers as suitable for the sensitive normal loads. The final decision on the selected route would be based on a combination of cost, distance and road condition at the time of transport.
- Transformer and substation components will be transported via abnormal loads. An abnormal load will necessitate an application to the *Department of Transport and Public Works* for a permit. A permit is required for each province that the transportation route traverses. Only 1-2 abnormal load trips per site is expected for *Doornhoek 1 PV Facility*. Abnormal load transportation is therefore considered to be isolated and would have a negligible impact on traffic over the construction phase of the project.
- In terms of impact on roads infrastructure:
 - It is proposed that the access roads in close proximity to the site be investigated for rehabilitation prior to construction and be maintained during construction in order to mitigate against the possibility of damaged goods due to poor road infrastructure.
 - The formalisation of the site access point, will likely be a requirement as part of the wayleave approval of the local and provincial roads authorities.
 - Adequate traffic accommodation signage must be erected and maintained on either side of the access throughout the construction period of the project.
 - While no construction of the PV facility occurs within the servitude, the construction and provision of internal roads that cross the servitude need to be according to Eskom wayleave requirements.
- In terms of impact on traffic:
 - The regional construction trips will be insignificant when compared to the Average Daily Traffic (ADT) and will not affect the existing Level of Service (LOS). It can therefore be concluded that, in terms of estimated traffic volumes, no mitigation measures will be necessary. Mitigation measures, such as staggered trips and reduced peak time travel are proposed if needed.
- In terms of cumulative impact:
 - The concurrent construction of *Doornhoek 1 PV Facility* and *Doornhoek 2 PV Facility* is considered to have a low impact. Mitigation measures that may be considered include the staggering of trips at the site and the implementation of a roads maintenance programme.

- The unlikely concurrent construction of four other solar farms in a 30 km radius of the site has also been considered. Only the regional trips were considered as it would be possible that the same port of entry would be considered for these sites. The local trips were not considered as these neighbouring solar farm developments, while in close proximity to each other, might not share the same primary study area. This impact is considered to be low.

The development of the *Doornhoek 1 PV Facility* on Portion 18 of the Farm Doornhoek No. 372-IP near Klerksdorp in the North West Province can therefore be supported from a traffic engineering perspective.

APPENDIX A

BACKGROUND TRAFFIC VOLUMES

Traffic Estimation

LOS based on 4-lane ADT

Lanes		1990 - ESTCOURT IC (N3)						
YEAR	AVERAGE DAILY TRAFFIC (ADT)			AVERAGE DAILY TRUCK TRAFFIC (ADTT)			TOTAL	
	TO SPRINGBOK	TO CAPE TOWN	TOTAL	TO SPRINGBOK	TO CAPE TOWN	TOTAL		
2015								
2016	8933	9178	18111	3351	3315	6666		
2017	9022	8911	17933	3375	3394	6769		
2018								
2019	8847	8764	17611	3590	3897	7487	42.5%	
2020	8544	8893	17437	3794	3949	7742		
2021	8463	8808	17271	3934	4094	8028		
2022	8381	8724	17105	4074	4240	8314		
2023	8300	8639	16939	4214	4386	8600		
2024	8219	8554	16773	4354	4532	8886		
2025	8138	8470	16608	4494	4677	9172		
2026	8056	8385	16442	4634	4823	9457		

Southern side of Giants Castle I/C

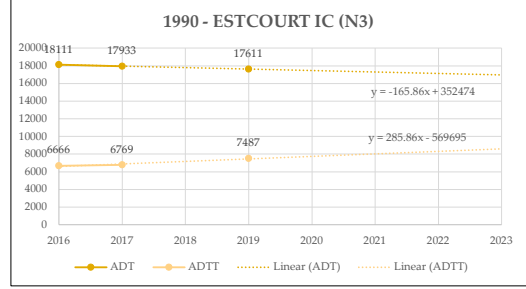

Lanes		533 - BETHLEHEM EAST (N5)						
YEAR	AVERAGE DAILY TRAFFIC (ADT)			AVERAGE DAILY TRUCK TRAFFIC (ADTT)			TOTAL	
	TO KESTELL	TO BETHLEHEM	TOTAL	TO KESTELL	TO BETHLEHEM	TOTAL		
2015	2467	2484	4951	642	625	1267		
2016	2502	2542	5044	612	627	1239		
2017	2550	2572	5122	652	649	1301		
2018	2542	2545	5087	666	658	1324		
2019	2505	2515	5020	701	692	1393	27.7%	
2020	2540	2559	5099	705	701	1406		
2021	2549	2568	5117	722	718	1440		
2022	2558	2577	5135	739	734	1473		
2023	2567	2586	5153	756	751	1507		
2024	2576	2595	5171	773	768	1541		
2025	2585	2604	5190	790	785	1575		
2026	2594	2613	5208	807	802	1608		

Between Kestell and Bethlehem

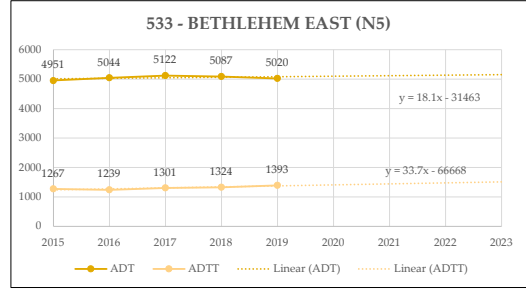

Lanes		875 - BETHLEHEM (N5)						
YEAR	AVERAGE DAILY TRAFFIC (ADT)			AVERAGE DAILY TRUCK TRAFFIC (ADTT)			TOTAL	
	TO HARRISMITH	TO WINBURG	TOTAL	TO HARRISMITH	TO WINBURG	TOTAL		
2015	1907	2015	3922	402	440	842		
2016	2033	2108	4141	453	476	929		
2017	2103	2151	4254	458	487	945		
2018	2121	2159	4280	500	520	1020		
2019	2144	2186	4330	532	556	1088	25.1%	
2020	2191	2281	4472	559	581	1140		
2021	2238	2329	4568	587	611	1198		
2022	2285	2378	4663	616	641	1257		
2023	2332	2427	4759	644	671	1315		
2024	2378	2476	4854	673	700	1373		
2025	2425	2524	4950	701	730	1432		
2026	2472	2573	5045	730	760	1490		

5 km west of Bethlehem

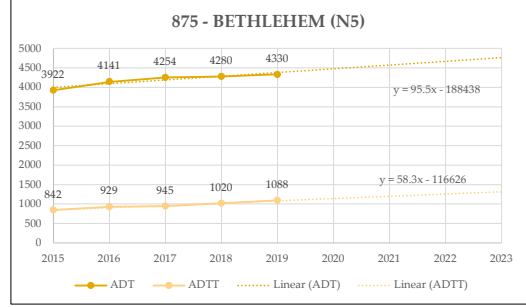

Traffic Estimation

1337 - TOUWS RIVER WEST			
Lanes	YEAR	ADT	ADTT
2	2015	634	183
LOS	2016	665	175
	2017	661	186
	2018	659	174
	2019	689	194
	2020	693	189
	2021	703	191
A	2022	714	193
	2023	724	195
	2024	735	197
	2025	745	199
	2026	755	201
A	2027	766	203

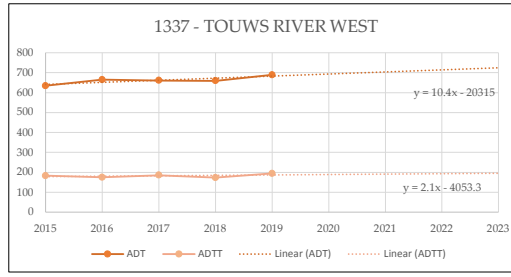

5066 - PGWC CERES KAROO			
Lanes	YEAR	ADT	ADTT
2	2015	242	46
LOS	2016	227	25
	2017	205	18
	2018	223	25
	2019	328	56
	2020	295	40
	2021	312	42
A	2022	329	44
	2023	345	46
	2024	362	48
	2025	379	50
	2026	396	52
A	2027	413	54

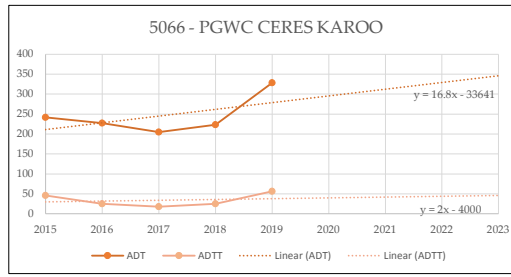

APPENDIX B

TYPICAL ACCESS GEOMETRY

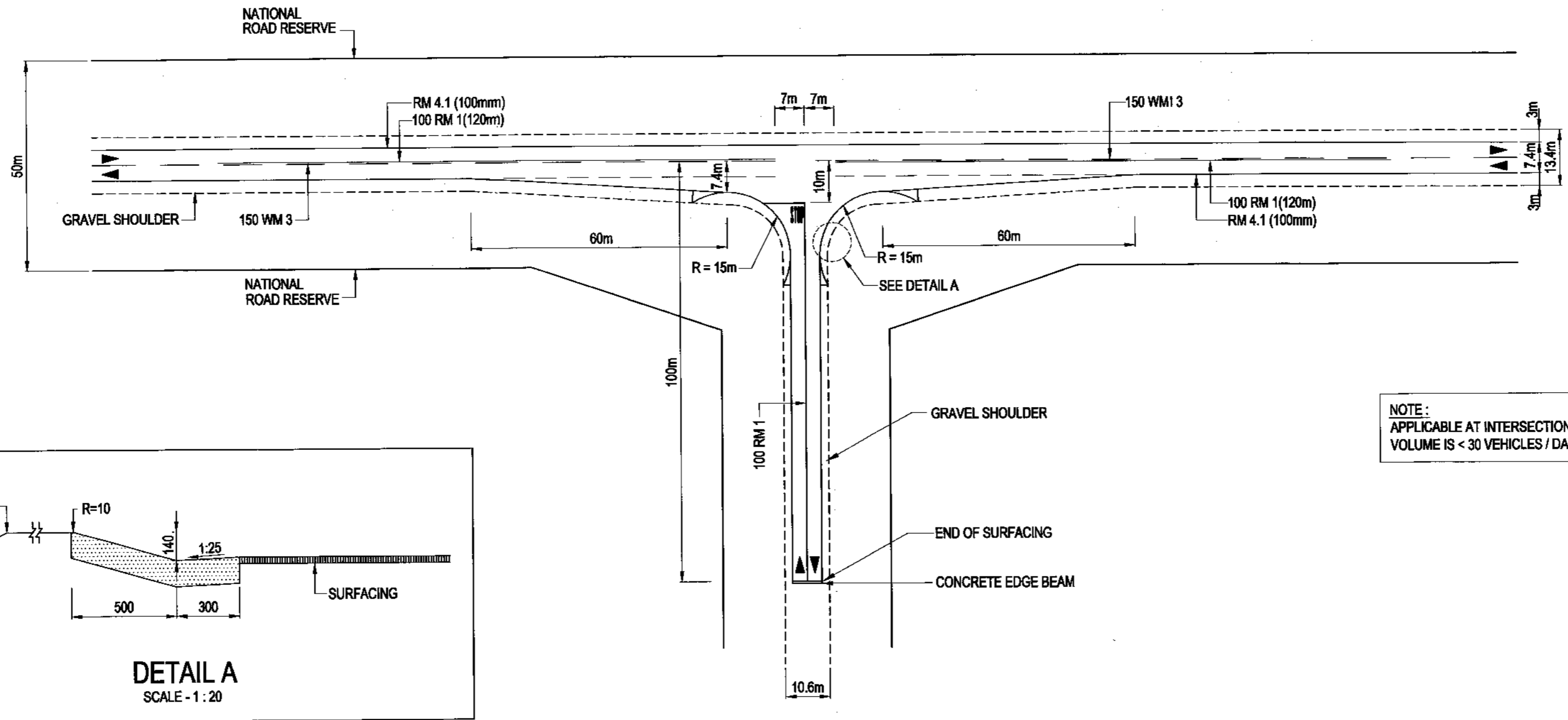

ROAD MARKING LEGEND	
RM 1	= NO OVERTAKING LINE
RM 4.1	= LEFT EDGE LINE
WM 3	= DIVIDING LINE

NOTE:
APPLICABLE AT INTERSECTIONS WHERE THE RIGHT TURNING VOLUME IS < 30 VEHICLES / DAY.

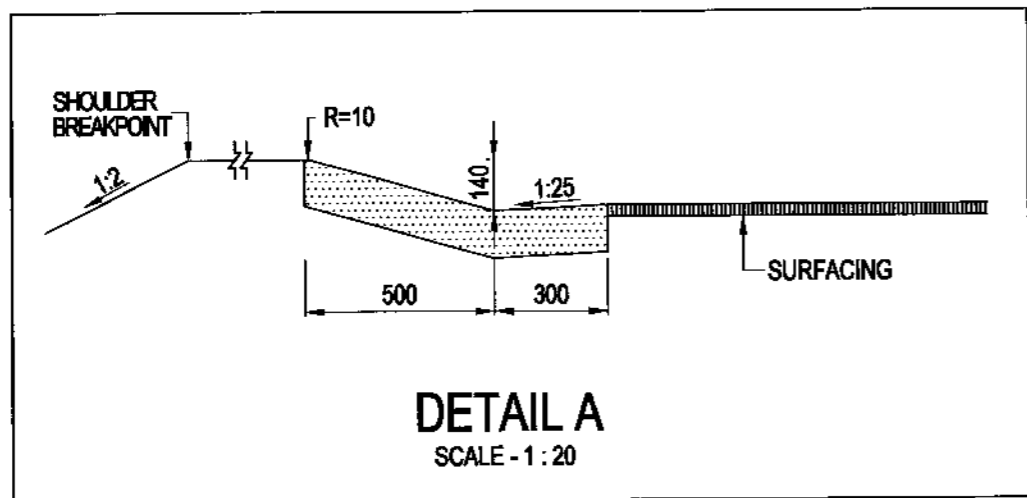
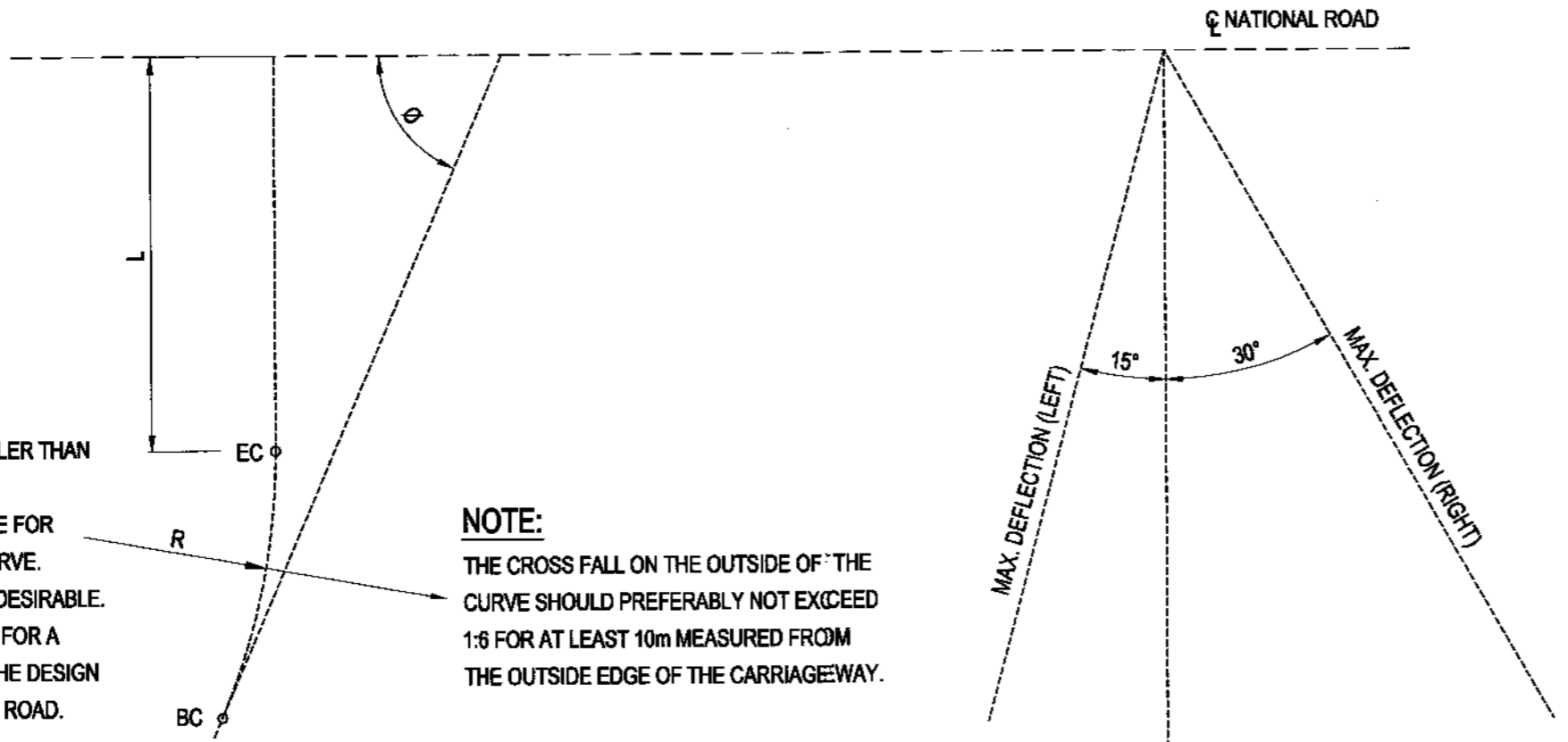

TABLE 1 SHOULDER SIGHT DISTANCE FOR STOP CONDITIONS	
DESIGN SPEED (THROUGH ROAD) (km/h)	SIGHT DISTANCE (D) (m)
50	150
60	180
70	210
80	240
90	270
100	300
110	330
120	360



- NOTE**
- θ = DEFLECTION ANGLE SMALLER THAN SAFE ANGLE.
 - L = STOPPING SIGHT DISTANCE FOR DESIGN SPEED FOR LAST CURVE. MINIMUM LENGTH OF 155m IS DESIRABLE.
 - R = CORRESPONDING RADIUS FOR A SPEED 15km/h LOWER THAN THE DESIGN SPEED FOR THE REST OF THE ROAD.

NOTE:
THE CROSS FALL ON THE OUTSIDE OF THE CURVE SHOULD PREFERABLY NOT EXCEED 1:6 FOR AT LEAST 10m MEASURED FROM THE OUTSIDE EDGE OF THE CARRIAGEWAY.

SAFE ANGLES AND STOPPING SIGHT DISTANCE AT T-JUNCTIONS
SCALE - N.T.S

- NOTE:**
- GRADIENT ON BOTH ROADS SHOULD NOT EXCEED 3%, ESPECIALLY ON THE JUNCTION LEG.
 - TABLE 1 CAN BE USED AS A BASIC GUIDELINE ON CONDITION THAT THE GRADIENTS ON BOTH THE JUNCTION AND PRIMARY ROADS DO NOT EXCEED 2%. THE SIGHT DISTANCE MUST BE MEASURED FROM AN EYE LEVEL OF 1,05m FROM A POINT 2m BEFORE THE STOP LINE ON THE JUNCTION ROAD TO AN OBJECT HEIGHT ON THE CENTRE LINE OF THE NATIONAL ROAD OF 1,30m.
 - THE DESIRABLE MINIMUM SIGHT DISTANCE IS 300m.
 - FOR DETAIL OF ROAD MARKINGS REFER TO THE SADC ROAD TRAFFIC SIGNS MANUAL.
 - THIS PLAN SERVES AS A GUIDE LINE AND WELL MOTIVATED DEVIATIONS MAY BE CONSIDERED.
 - WHERE APPLICABLE CROSS-SECTION DIMENSIONS MUST BE ADJUSTED ACCORDING TO THE APPROVED TYPICAL CROSS-SECTION BEING USED.

FOR LATEST VERSION CHECK www.nra.co.za

No.	DATE	VERSION / REVISION	APPROVED
V1	SEPT 2014	ORIGINAL VERSION	

SANRAL TYPICAL DRAWINGS

COPYRIGHT: THIS DRAWING IS PROTECTED IN TERMS OF THE COPYRIGHT ACT No. 98 OF 1978 AND MAY NOT BE REPRODUCED WITHOUT PERMISSION IN WRITING FROM SANRAL.

CONDITIONS FOR USE: CONSULTANTS APPOINTED BY SANRAL SHALL INCORPORATE THE TYPICAL DETAILS HEREON INTO THEIR SPECIFIC DESIGN FOR WHICH THEY WILL ASSUME FULL PROFESSIONAL RESPONSIBILITY. THIS TYPICAL DRAWING MAY NOT BE USED FOR TENDER PURPOSES.

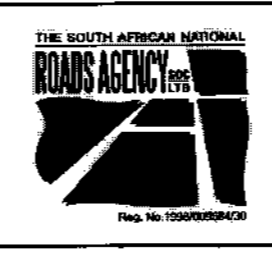

HEAD OFFICE
48 Tambolle Avenue
Val de Grace
Pretoria
0184
PO Box 415
Pretoria 0001
South Africa
Tel: (012) 844 8000

W. v. d. Merwe
APPROVED
DATE: 2015/06/26

TYPICAL DRAWINGS - ROADWORKS
T - JUNCTIONS & INTERSECTIONS
T - JUNCTION WITH GRAVEL
CLASS 2 ROADS

SANRAL DOC. No. (PDF)	1693224
SANRAL DOC. No. (DWG)	1797268
SANRAL DRAWING No.	TD-R-JI-1100-V1

APPENDIX C

ASSESSMENT METHODOLOGY

Assessment of Impacts

Direct, indirect and cumulative impacts associated with the projects must be assessed in terms of the following criteria:

- The **nature**, which shall include a description of what causes the effect, what will be affected and how it will be affected.
- The **extent**, wherein it will be indicated whether the impact will be local (limited to the immediate area or site of development) or regional, and a value between 1 and 5 will be assigned as appropriate (with 1 being low and 5 being high):
- The **duration**, wherein it will be indicated whether:
 - the lifetime of the impact will be of a very short duration (0–1 years) – assigned a score of 1;
 - the lifetime of the impact will be of a short duration (2-5 years) - assigned a score of 2;
 - medium-term (5–15 years) – assigned a score of 3;
 - long term (> 15 years) - assigned a score of 4; or
 - permanent - assigned a score of 5;
- The **magnitude**, quantified on a scale from 0-10, where 0 is small and will have no effect on the environment, 2 is minor and will not result in an impact on processes, 4 is low and will cause a slight impact on processes, 6 is moderate and will result in processes continuing but in a modified way, 8 is high (processes are altered to the extent that they temporarily cease), and 10 is very high and results in complete destruction of patterns and permanent cessation of processes.
- The **probability** of occurrence, which shall describe the likelihood of the impact actually occurring. Probability will be estimated on a scale of 1–5, where 1 is very improbable (probably will not happen), 2 is improbable (some possibility, but low likelihood), 3 is probable (distinct possibility), 4 is highly probable (most likely) and 5 is definite (impact will occur regardless of any prevention measures).
- The **significance**, which shall be determined through a synthesis of the characteristics described above and can be assessed as low, medium or high; and
- the status, which will be described as either positive, negative or neutral.
- the degree to which the impact can be reversed.
- the degree to which the impact may cause irreplaceable loss of resources.
- the degree to which the impact can be mitigated.

The significance is calculated by combining the criteria in the following formula:

$$S=(E+D+M)P$$

S = Significance weighting

E = Extent

D = Duration

M = Magnitude

P = Probability

The **significance weightings** for each potential impact are as follows:

- < 30 points: Low (i.e. where this impact would not have a direct influence on the decision to develop in the area),
- 30-60 points: Medium (i.e. where the impact could influence the decision to develop in the area unless it is effectively mitigated),
- > 60 points: High (i.e. where the impact must have an influence on the decision process to develop in the area).

Assessment of Cumulative Impacts

As per DEA's requirements, specialists are required to assess the cumulative impacts. In this regard, please refer to the methodology below that will need to be used for the assessment of Cumulative Impacts.

"Cumulative Impact", in relation to an activity, means the past, current and reasonably foreseeable future impact of an activity, considered together with the impact of activities associated with that activity, that in itself may not be significant, but may become significant when added to existing and reasonably foreseeable impacts eventuating from similar or diverse activities .

The role of the cumulative assessment is to test if such impacts are relevant to the proposed project in the proposed location (i.e. whether the addition of the proposed project in the area will increase the impact). This section should address whether the construction of the proposed development will result in:

- Unacceptable risk
- Unacceptable loss
- Complete or whole-scale changes to the environment or sense of place
- Unacceptable increase in impact

The specialist is required to conclude if the proposed development will result in any unacceptable loss or impact considering all the projects proposed in the area.

DOORNHOEK PV (PTY) LTD

**TRAFFIC IMPACT ASSESSMENT FOR THE PROPOSED
DOORNHOEK 2 PV FACILITY AS PART OF THE
DOORNHOEK PHOTOVOLTAIC CLUSTER NEAR
KLERKSDORP, NORTH WEST PROVINCE**

34503.01C-REP-002-01

TRAFFIC IMPACT ASSESSMENT

APRIL 2022

PREPARED FOR:

DOORNHOEK PV (PTY) LTD
101 BLOCK A, WEST QUAY BUILDING
7 WEST QUAY ROAD, WATERFRONT
CAPE TOWN
8000

PREPARED BY:



**BVi CONSULTING ENGINEERS WESTERN
CAPE (PTY) LTD**
BLOCK B2, EDISON SQUARE
C/O EDISON WAY AND CENTURY AVENUE
CENTURY CITY
7441

EXECUTIVE SUMMARY

BVi Consulting Engineers Western Cape (Pty) Ltd was appointed by *Doornhoek PV (Pty) Ltd* to conduct a Traffic and Transportation Assessment for the proposed development of the *Doornhoek Solar PV Cluster* on Portion 18 of the Farm Doornhoek No. 372-IP near Klerksdorp, in the North West Province. This proposed cluster is made up of two adjacent photovoltaic (PV) facilities of 115 MW and 50 MW per facility respectively. This specialist study forms part of the requirements for the Draft Basic Assessment Report, and assesses the *Doornhoek 2 PV Facility* (50 MW plant), the southern and eastern facility of the cluster.

For the traffic assessment, regional and local transport routes were investigated:

- For regional routes, haulage routes from various ports of entry (Durban Harbour and Saldanha Bay Harbour) were investigated. A regional route from Johannesburg has also been assessed and presented for the haulage of major electrical components.
- For the assessment of local routes, routes close to the site were assessed for impact of local trips on the local network.
- The existing traffic volumes on the transportation routes were sourced and used to calculate the current background traffic, the expected background traffic during construction and, thereby, the Level of Service. The number of trips generated from the construction period were estimated and the impact of these additional trips on the regional and local transport routes were also investigated.

An additional up to 115 MW PV facility (*Doornhoek 1 PV Facility*) is concurrently being considered on the same property and is being assessed through a separate Basic Assessment (BA) process. The cumulative impact of the concurrent development of these two facilities was assessed in terms of traffic.

The following conclusions were drawn from the study:



- The major traffic impact occurs during the construction phase of the project. The impact of the construction trip generation, on the predicted traffic volumes on the local and the regional transportation routes are expected to be low. No mitigation measures for these routes will be necessary.
- The photovoltaic (PV) components will be delivered to site from two possible ports, either from Saldanha Bay Harbour over a distance of 1 340 km or from Durban Harbour over a distance of 665 km. The regional routes indicated in the analysis would need to be confirmed by freight carriers as suitable for the sensitive normal loads. The final decision on the selected route would be based on a combination of cost, distance and road condition at the time of transport.
- Transformer and substation components will be transported via abnormal loads. An abnormal load will necessitate an application for a permit. Only 1-2 abnormal load trips per site is expected for *Doornhoek 2 PV Facility*. Abnormal load transportation is therefore considered to be isolated and would have a negligible impact on traffic over the construction phase of the project.

- In terms of impact on roads infrastructure:
 - It is proposed that the access roads in close proximity to the site be investigated for rehabilitation prior to construction and be maintained during construction in order to mitigate against the possibility of damaged goods due to poor road infrastructure.
 - The site access point will likely need to be formalised, as a requirement as part of the wayleave approval of the local and provincial roads authorities.
 - Adequate traffic accommodation signage must be erected and maintained on either side of the access throughout the construction period of the project.
 - The construction and provision of internal roads that cross the Eskom servitude need to be according to Eskom wayleave requirements.
- In terms of impact on traffic:
 - The regional construction trips will be insignificant when compared to the Average Daily Traffic (ADT) and will not affect the existing Level of Service (LOS). Mitigation measures, such as staggered trips and reduced peak time travel are proposed if needed.
- In terms of cumulative impact:
 - The concurrent construction of *Doornhoek 1 PV Facility* and *Doornhoek 2 PV Facility* is considered to have a low impact. Mitigation measures that may be considered include the staggering of trips at the site and the implementation of a roads maintenance programme.
 - The unlikely concurrent construction of four other solar farms in a 30 km radius of the site has also been considered to be low.

The development of the *Doornhoek 2 PV Facility* on Portion 18 of the Farm Doornhoek No. 372-IP near Klerksdorp in the North West Province can therefore be supported from a traffic engineering perspective.

ISSUE AND REVISION RECORD

QUALITY APPROVAL

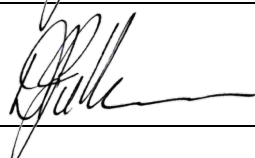
	CAPACITY	NAME	SIGNATURE	DATE
By author	Engineer	Lee-Ann Petersen Pr Eng: 20180198		26/04/2022
Checked by	Professional Engineering Technologist	Jacques Nel Pr Tech Eng: 200770131	pp 	26/04/2022
Approved by Design Centre Leader	Director	Dirk van der Merwe Pr Eng: 20120186		26/04/2022

This report has been prepared in accordance with BVi Consulting Engineers Quality Management System. BVi Consulting Engineers is ISO 9001: 2015 registered and certified by NQA Africa.



REVISION RECORD

REVISION NUMBER	OBJECTIVE	CHANGE	DATE
0	Issue to Client for review	None	19/04/2022
1	Address Client feedback	Minor details from pdf mark-ups	26/04/2022

TABLE OF CONTENTS

EXECUTIVE SUMMARY	ii
ISSUE AND REVISION RECORD.....	iv
CHAPTER 1 INTRODUCTION.....	1
1.1 TERMS OF REFERENCE.....	1
1.2 OBJECTIVES	1
1.3 APPROACH AND METHODOLOGY	1
1.4 ASSUMPTIONS AND LIMITATIONS.....	2
1.5 REFERENCE DOCUMENTATION	2
CHAPTER 2 PROJECT PARTICULARS	3
2.1 PROJECT DESCRIPTION AND SITE LOCATION	3
2.2 EXISTING ROAD NETWORK	4
2.3 PROPOSED SITE LAYOUT	5
2.4 PROPOSED SITE ACCESS ROAD AND INTERNAL ROADS	5
CHAPTER 3 TRANSPORTATION ROUTES	7
3.1 OVERVIEW	7
3.2 LEGISLATION AND PERMIT REQUIREMENTS	7
3.3 HAULAGE FROM PORTS OF ENTRY	9
3.4 HAULAGE OF TRANSFORMER AND SUBSTATION COMPONENTS.....	12
3.5 HAULAGE OF OTHER PLANT, CONSTRUCTION MATERIAL AND EQUIPMENT.....	13
3.6 TRANSPORT OF CONSTRUCTION PERSONNEL	13
3.7 ROUTE CLEARANCE.....	13
3.8 SUMMARY	13
CHAPTER 4 BACKGROUND TRAFFIC VOLUMES	15
4.1 OVERVIEW	15
4.2 REGIONAL TRAFFIC	15
4.3 LOCAL TRAFFIC.....	16
4.4 CAPACITY ANALYSIS.....	17
CHAPTER 5 TRIP GENERATION.....	18
5.1 OVERVIEW	18
5.2 CONSTRUCTION PHASE.....	18
5.3 OPERATIONAL PHASE.....	19
5.4 DECOMMISSIONING PHASE	19
CHAPTER 6 TRAFFIC IMPACT ASSESSMENT.....	20
6.1 OVERVIEW	20
6.2 ASSESSMENT OF IMPACTS ON REGIONAL TRANSPORTATION ROUTES.....	20

6.3	ASSESSMENT OF IMPACTS ON LOCAL TRAFFIC.....	20
CHAPTER 7 IMPACT ASSESSMENT SUMMARY		22
7.1	OVERVIEW	22
7.2	IMPACT ASSESSMENT – CONSTRUCTION PHASE REGIONAL TRAFFIC	22
7.3	IMPACT ASSESSMENT – CONSTRUCTION PHASE LOCAL TRAFFIC.....	23
7.4	IMPACT ASSESSMENT – SITE ROADS INFRASTRUCTURE	24
7.5	IMPACT ASSESSMENT – OPERATIONAL PHASE TRAFFIC.....	25
CHAPTER 8 CUMULATIVE IMPACT ASSESSMENT		26
8.1	OVERVIEW	26
8.2	CUMULATIVE IMPACT – DOORNHOEK PV CLUSTER	26
8.3	CUMULATIVE IMPACT – SOLAR FARM DEVELOPMENT IN 30km RADIUS	27
CHAPTER 9 SUMMARY AND CONCLUSION		29
9.1	SUMMARY	29
9.2	CONCLUSIONS.....	30
APPENDIX A BACKGROUND TRAFFIC VOLUMES.....		A
APPENDIX B TYPICAL ACCESS GEOMETRY		B
APPENDIX C ASSESSMENT METHODOLOGY.....		C

LIST OF TABLES

<i>Table 3.1: Permits and consent requirements</i>	9
<i>Table 4.1: Traffic recording stations (Port of Durban route)</i>	15
<i>Table 4.2: Traffic recording stations (Port of Saldanha route)</i>	16
<i>Table 4.3: Traffic recording stations near Klerksdorp</i>	16
<i>Table 4.4: Capacity analysis (background traffic)</i>	17
<i>Table 5.1: Trip generation (construction phase)</i>	19
<i>Table 6.1: Traffic impact on N12 and R30 (commuter trips)</i>	21
<i>Table 8.1: Additional solar power projects (within 30 km radius from study area)</i>	27

LIST OF FIGURES

<i>Figure 2.1: Locality of the Doornhoek PV Cluster near the town of Klerksdorp</i>	<i>3</i>
<i>Figure 2.2: Doornhoek 1 and 2 PV Facilities on Portion 18 of Farm Doornhoek No. 372-IP</i>	<i>4</i>
<i>Figure 2.3: Doornhoek 1 PV Facility and site access road.....</i>	<i>6</i>
<i>Figure 3.1: Transportation route (Port of Durban to Doornhoek PV Facility)</i>	<i>10</i>
<i>Figure 3.2: Transportation route (Port of Saldanha to Doornhoek PV Facility).....</i>	<i>11</i>
<i>Figure 3.3: Transportation route (Johannesburg to Doornhoek PV Facility)</i>	<i>12</i>

CHAPTER 1 INTRODUCTION

1.1 TERMS OF REFERENCE

BVi Consulting Engineers Western Cape (Pty) Ltd was appointed by *Doornhoek PV (Pty) Ltd* to conduct a traffic and transportation assessment for the proposed development of the *Doornhoek Solar PV Cluster* near Klerksdorp, in the North West Province. This proposed cluster is made up of two adjacent photovoltaic (PV) solar energy facilities (SEFs) of 115 MW and 50 MW per facility respectively. This specialist study forms part of the requirements for the Draft Basic Assessment Report and assesses the *Doornhoek 2 PV Facility* (50 MW plant).

1.2 OBJECTIVES

The objectives of this specialist traffic and transportation study are as follows:

- To identify the most optimal shipping port(s) and assess feasible transport routes, route lengths and potential constraints for facility components;
- To determine the potential indirect, direct and cumulative risks/ impacts to receptors from a traffic and transportation perspective for this project;
- To propose mitigation measures for identified significant risks/ impacts and enhance positive risk/ impacts of the project; and
- To ensure that the project operations comply with relevant social and environmental standards, policies, laws and regulations in terms of traffic and transportation.

1.3 APPROACH AND METHODOLOGY

The traffic and transportation study deals with the traffic impact on the surrounding road network during three distinct phases: *construction*, *operational* and *decommissioning*. The study considered and assessed the following:

- Site layout, access points and internal roads assessment:
 - Description of the surrounding road network;
 - Description of site layout;
 - Assessment of proposed access points; and
 - Assessment of proposed internal roads.
- Traffic and transportation assessment:
 - Estimation of trip generation;
 - Discussion of potential traffic impacts;
 - Assessment of possible transportation routes; and
 - Assessment of construction and operational (maintenance) vehicle trips.

1.4 ASSUMPTIONS AND LIMITATIONS

The following assumptions and limitations apply to the traffic and transportation study:

- This study is based on the project information provided by the environmental consultants and project managers for the applicant, *Doornhoek PV (Pty) Ltd*;
- According to Eskom specifications for power transformers, the following dimensional limitations need to be adhered to when transporting the transformers:
 - Height: 5000 mm.
 - Width: 4300 mm and
 - Length: 10 500 mm.
- Imported PV energy facility components would be transported from the most feasible port of entry;
- If any elements are manufactured within South Africa, these would be transported from their respective manufacturing centres, which would be either in the greater Johannesburg, Pinetown/Durban or Cape Town for the transformer, inverter and the support structures;
- Civil construction materials would be sourced from nearby towns where possible;
- All other construction materials, for concrete and wearing course, would be sourced from a local licensed quarry (off-site);
- All transportation trips external to the development site would occur on existing surfaced or gravel roads; and
- Maximum vertical height clearances along the transportation route is 5.2 m for abnormal loads.

1.5 REFERENCE DOCUMENTATION

The following documents/sources were used in compiling this report and reference will be made where necessary:

- *Highway Capacity Manual (HCM) 6th Edition*, published by *Transportation Research Board*, October 2016.
- *TRH 11 – Dimensional and Mass Limitations and Other Requirements for Abnormal Load Vehicles*, published by Department of Transport (DoT), August 2009.
- *TMH 17, Volume 1 - South African Trip Data Manual*, published by the *Committee of Transport Officials (COTO)*, September 2012.
- *TRH 17 – Geometric Design of Rural Roads*, published by the *Department of Transport (DoT)*, 1988.

CHAPTER 2 PROJECT PARTICULARS

2.1 PROJECT DESCRIPTION AND SITE LOCATION

The Applicant, *Doornhoek PV (Pty) Ltd*, is proposing the construction of a photovoltaic (PV) solar energy facility (known as the *Doornhoek 2 PV Facility*) located on a site approximately 11 km north of Klerksdorp in the North West Province. The solar PV facility will comprise several arrays of PV panels and associated infrastructure and will have a contracted capacity of up to 50 MW. The development area is situated within the *City of Matlosana Local Municipality* within the *Dr Kenneth Kaunda District Municipality*.

The site for this development is located off a local district road to the east of the development area, which provides multiple farms with access to the greater road network. The access road links to District Road in Klerksdorp, to the south of the site. The nearest regional and national routes are the R30 and the N12 respectively, which are the main routes to Klerksdorp. The location of the site is provided in *Figure 2.1* below.

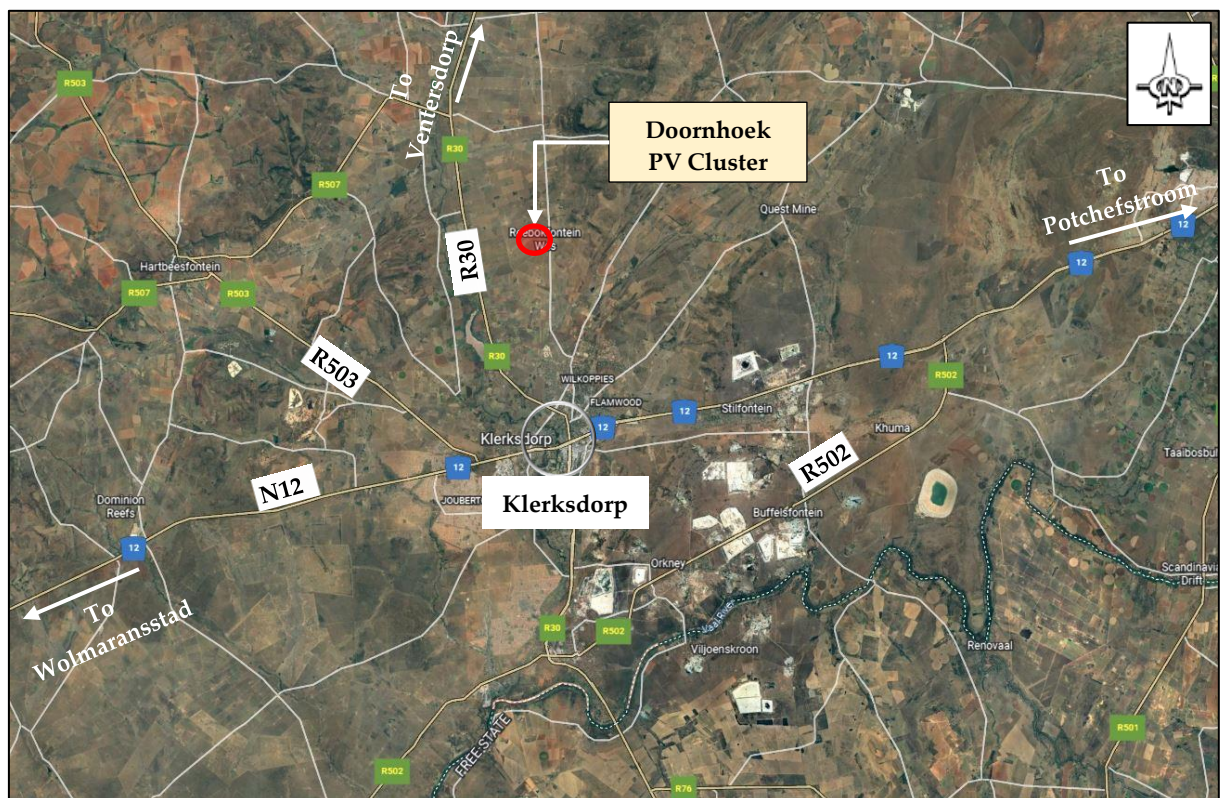

Figure 2.1: Locality of the Doornhoek PV Cluster near the town of Klerksdorp

The proposed *Doornhoek 2 PV Facility* and associated infrastructure will be located on Portion 18 of the Farm Doornhoek No. 372-IP. The project site is located within the Klerksdorp Renewable Energy Development Zones (REDZ), and therefore, a Basic Assessment (BA) process will be undertaken in accordance with GN R114 (as formally gazetted on 16 February 2018).

An additional 115 MW PV facility (*Doornhoek 1 PV Facility*) is concurrently being considered on the same property and is being assessed through a separate Basic Assessment (BA) process. The layout of the cluster is indicated in the figure below.

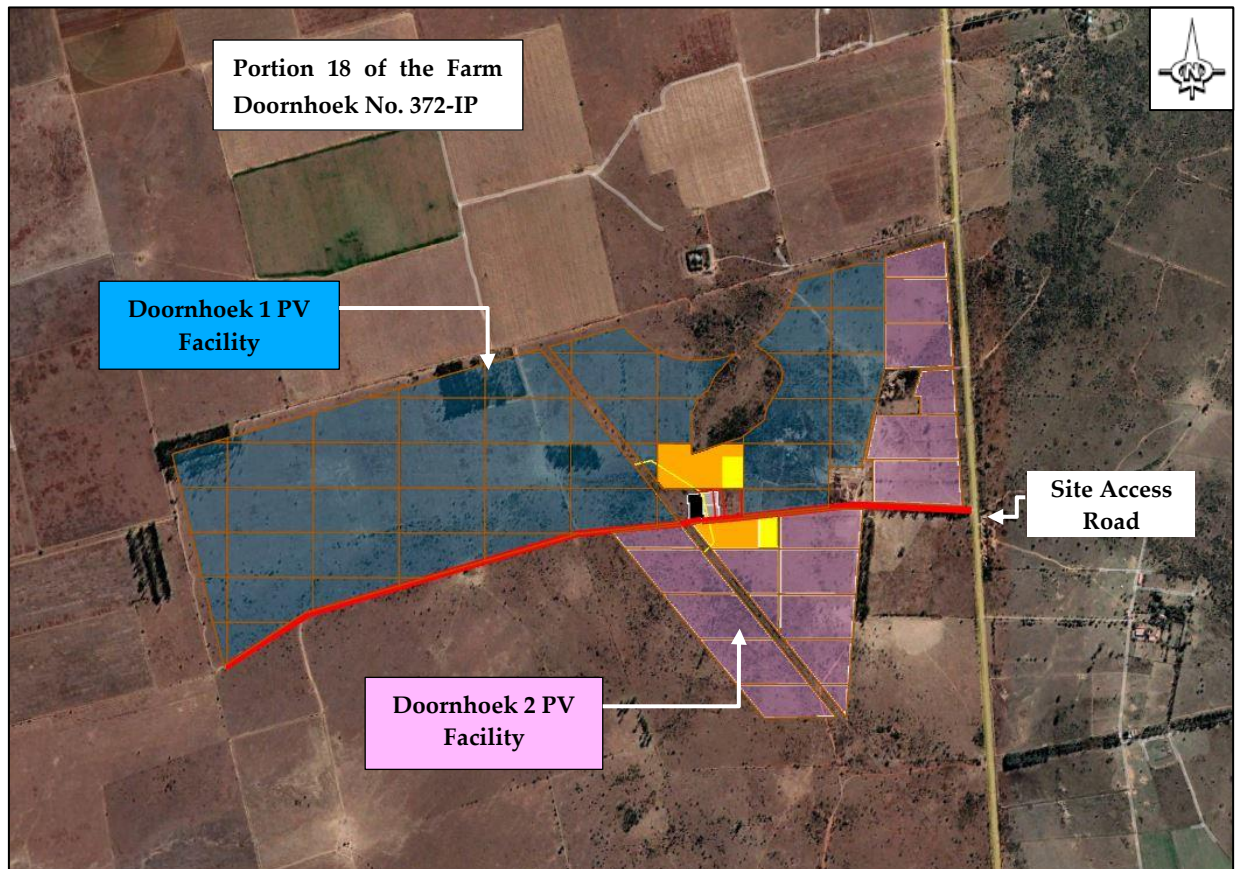

Figure 2.2: Doornhoek 1 and 2 PV Facilities on Portion 18 of Farm Doornhoek No. 372-IP

The proposed *Doornhoek 1 PV Facility* will cover approximately 200 ha and the *Doornhoek 2 PV Facility* will cover approximately 80 ha. This report addresses the traffic impact for the *Doornhoek 2 PV Facility*.

2.2 EXISTING ROAD NETWORK

The site for this development is located off a local district road, which provides multiple farms in the area with access to the greater road network. The road is a two-lane surfaced road. Images from *Google Street View* indicate gravel shoulders.

This access road links to District Road in Klerksdorp, to the south of the site. The major routes in the immediate vicinity of the site are the R30 to the west of the site, N12 to the south of the site and R507 to the north-west of the site.

2.3 PROPOSED SITE LAYOUT

The proposed *Doornhoek 2 PV Facility* will cover approximately 80 ha and will include the following infrastructure:

- PV modules and mounting structures;
- Inverters and transformers;
- Battery Energy Storage System (BESS);
- Site and internal access roads (up to 8m wide);
- Operation and maintenance buildings including a gate house and security building, control centre, offices, warehouses and workshops for storage and maintenance;
- Temporary and permanent laydown area;
- Grid connection infrastructure, including:
 - 33kV cabling between the project components and the facility substation;
 - A 132kV facility substation;
 - A 132kV Eskom switching station; and
 - A Loop-in-Loop-out (LILO) overhead 132kV power line between the Eskom switching station and the existing Watershed–Klerksdorp 1 132kV power line.

The proposed layout is considered as a consideration for the estimation of construction and operational traffic.

2.4 PROPOSED SITE ACCESS ROAD AND INTERNAL ROADS

Access to the site will be via an existing gravel road, which is proposed to be 8 m wide. This access road will need to be investigated for rehabilitation prior to construction to cater for the construction vehicles navigating the road to the laydown areas on site.

This gravel road will need to be suitably maintained. This process would also provide mitigation against the possibility of damaged goods due to poor road infrastructure. Re-gravelling may be necessary as a maintenance measure, from time to time, throughout the operational life of the solar power plant. The site access road is provided in *Figure 2.2* below.

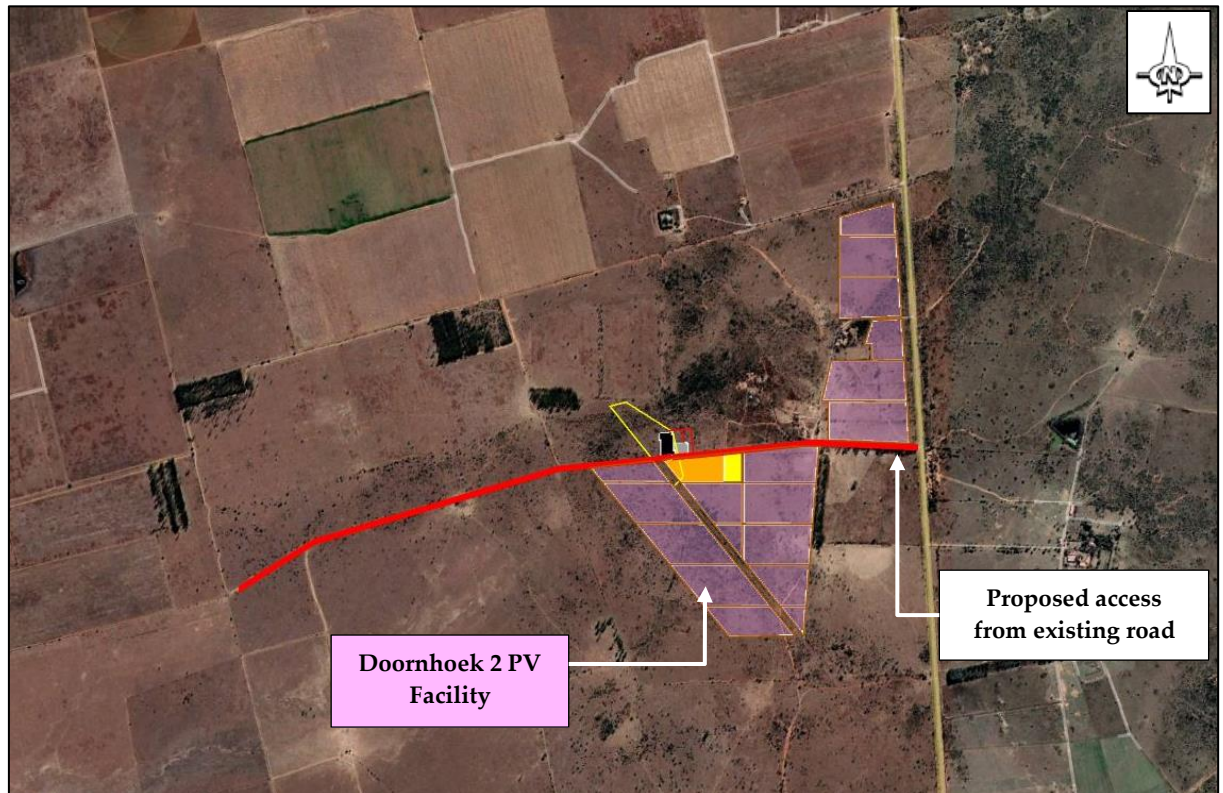

Figure 2.3: Doornhoek 2 PV Facility and site access road

The formalisation and upgrading of the access point to the required standard, as provided in *Appendix B*, will in all probability be a requirement as part of the wayleave approval of *City of Matlosana Local Municipality* and *North West: Department of Public Works and Roads*.

The secondary internal roads are proposed to be 4 m wide (maximum 5 m wide), following the grid layout as indicated in the figure above. It has also been noted that the site layout crosses an Eskom servitude. While no construction of the PV facility occurs within the servitude, the construction and provision of internal roads that cross the servitude need to be according to Eskom wayleave requirements.

In addition, it must be noted that adequate traffic accommodation signage must be erected and maintained on either side of the access throughout the construction phase of the plant, in accordance with the *South African Road Traffic Signs Manual, Vol 2, May 2012*.

CHAPTER 3 TRANSPORTATION ROUTES

3.1 OVERVIEW

Local and regional transportation routes are impacted by the proposed development. Due to the nature of the project, haulage routes from the port of entry for imported PV and related components as well as haulage along local routes for locally sourced construction materials is considered.

The bulk of the haulage would consist of normal heavy vehicles. Abnormal loads are foreseen for the transport of electrical components for the construction of the proposed transformers on the site. The impact of and requirements for abnormal loads are also highlighted.

3.2 LEGISLATION AND PERMIT REQUIREMENTS

The overarching environmental legislation for management of the environment in South Africa, is the *National Environmental Management Act, 1998 (Act 107 of 1998 "NEMA")*. Its foreword states that sustainable development requires the integration of social, economic, and environmental factors in the planning, implementation, and evaluation of environmental decisions to ensure that the development serves present and future generations. Traffic impacts are therefore an important aspect to consider in the decision-making process of developments.

3.2.1 Roads

The relevant legislation associated with the road (infrastructure), transportation and traffic include, inter alia:

- National Water Act (Act 36 of 1998), with regards to all crossings of water courses.
- National Road Traffic Act (Act 93 of 1996).
- National Road Traffic Regulations, 2000.
- Advertising on Road and Ribbon Development Act (Act 21 of 1940).
 - Section 9: Prohibition of erection of structures or construction of other things near intersections of certain roads, and
 - Section 10: Restriction of access to land through fence along certain roads.
- Roads Ordinance Act (Act 19 of 1976).
 - Section 13: Erection of gates across public roads and public paths.
 - Section 17: Erection of structures on or near public roads, and
 - Section 18: Access to and exit from certain public roads and public paths.

3.2.2 Vehicle dimensions

Regulations 221 to 230 of the *National Road Traffic Act* relates to vehicle dimensions. The most important points are summarised below.

- Regulation 221: Defines the legislation requirements regarding the overall length of vehicles. The following lengths shall not be exceeded:
 - Rigid vehicle: 12.5 m.
 - Articulated vehicle and semi-trailer: 18.5 m; and
 - Combination vehicle (interlinks, multiple trailers etc.): 22.0 m
- Regulation 223: Defines the legislation requirements regarding the overall width of vehicles. Vehicles with a gross mass of 12 000 kg or more, shall not exceed 2.6 m.
- Regulation 224: Define the legislation requirements regarding the overall height of a vehicle and transported load, which shall not exceed 4.3 m.
- Regulation 225: Defines the legislation requirements regarding the maximum turning radius and wheelbase, which shall not exceed 13.1 m or 10.0 m (semi-trailer) respectively.

3.2.3 Vehicle loads

Regulations 231 to 249 of the *National Road Traffic Act* relates to vehicle loads. The most important points are summarised below.

- Regulation 240: Defines the legislation requirements regarding the mass load carrying on roads.
- Regulation 241: Defines the legislation requirements regarding the mass load carrying capacity of bridges.

3.2.4 Abnormal load considerations

It is expected that the transformers will be transported with an abnormal load vehicle. Abnormal permits are required for vehicles exceeding the permissible maximum dimensions on road freight transport.

The *National Road Traffic Act (Act 93 of 1996)* and the *National Road Traffic Regulations (2000)* prescribed certain limitations on vehicle dimensions and axle and vehicle masses that a vehicle using a public road must comply with. Where the prescribed limitations are exceeded, these loads are then classified as an abnormal load. Provision for such abnormal vehicles and loads are made in *Section 81 of the National Road Traffic Act*, as substituted by *Section 23 of the National Road Traffic Amendment Act (Act 64 of 2008)*.

The requirements and procedures for transporting of abnormal loads are contained in the following two documents:

- *TRH 11: Dimensional and Mass Limitations and Other Requirements for Abnormal Load Vehicles;* and
- *COTO: Administrative Guidelines for Granting of Exemption Permits for the Conveyance of Abnormal Loads, Revision 2, March 2015.*

The specific permits and consents that may be required from the relevant authorities, for the transportation of abnormal loads, are summarised in *Table 3.1* below.

Table 3.1: Permits and consent requirements

PERMIT/ CONSENT TYPE	RELEVANT AUTHORITY	STRATEGY
Abnormal Load/Vehicle Permit in terms of <i>National Road Traffic Act 93 of 1996, Section 81</i>	<i>Department of Transport: Kwa-Zulu Natal; Department Of Police, Roads And Transport – Free State Provincial Government; Department of Transport, Roads and Community Safety – Provincial Government North West; and Gauteng: Department of Roads</i>	The freight contractor will obtain the necessary road transportation permits.
<i>The South African National Roads Agency Limited and National Roads Act, Act 7 of 1998</i>	<i>South African National Roads Agency SOC Limited (SANRAL)</i>	The freight contractor will obtain the necessary road transportation permits from SANRAL.

It should be noted that embargo days for transportation of abnormal loads generally coincide with public holidays, start and end of school holidays and extended year-end periods. These dates are updated regularly for each provincial roads department.

As discussed further in the report, the number of abnormal load trips per site is considered negligible (1-2 trips per site) and does not have an impact on traffic but the abovementioned permits will still be required. A permit is, however, required for each province that the transportation route traverses.

3.3 HAULAGE FROM PORTS OF ENTRY

The closest port of entry for consideration is the Durban Harbour. An alternative port of entry that has been considered is the Saldanha Bay Harbour. The distance from the Durban Harbour is approximately 665 km and from Saldanha Bay Harbour measures approximately 1 340 km.

3.3.1 Alternative 1: Port of Durban (665 km)



Figure 3.1: Transportation route (Port of Durban to Doornhoek PV Facility)

The route overview shown in *Figure 3.2* (Source: Google Maps) is briefly described below:

- From Durban Harbour, take Langeberg Rd, Bayhead Rd and R102 to Edwin Swales Dr/Solomon Mahlangu Dr/M7 in Sea View. Exit from R102 (9.3 km);
- Follow N3 and N5 to Hospital Rd/R26 in Bethlehem (384 km);
- Take R76 and R30 to your destination in North West (271 km).

It should be noted that this route has tolls.

3.3.2 Alternative 2: Port of Saldanha (1 340 km)



Figure 3.2: Transportation route (Port of Saldanha to Doornhoek PV Facility)

The route overview shown in Figure 3.1 (Source: Google Maps) is briefly described below:

- From Saldanha Bay Harbour Take R45, R311, Gouda Rd and R46 to N1 in Western Cape (235 km);
- Follow N1 and N12 to Leemhuis St in Freemanville, Klerksdorp (1,089 km);
- Drive to your destination (15.5 km).

3.3.3 Recommended port of entry

In terms of transport and traffic impact, the recommended port of entry is considered to be Durban Harbour. It is currently the largest harbour in South Africa and is the closest harbour to the site. It is recognised that effort is being made to shift cargo from Durban Harbour to Richards Bay Harbour and East London Harbour. The Durban Harbour is proposed as the preferred harbour along the eastern coast.

Saldanha Bay Harbour is considered a suitable option on the western coast. The route has been analysed and shows routes along national roads, catering for freight transport.

The regional routes indicated in the analysis would need to be confirmed by freight carriers as suitable for the sensitive normal loads and for any abnormal loads. The final decision on the selected route would be based on a combination of cost, distance and road condition at the time of transport.

3.4 HAULAGE OF TRANSFORMER AND SUBSTATION COMPONENTS

Transformer and substation components are envisaged to form part of the regional trips. It is anticipated that these components would be imported and transported from the preferred harbour (Saldanha or Durban Harbour) as abnormal loads. It would very likely be assembled in Johannesburg and transported to the *Doornhoek 2 PV Facility* site, also requiring abnormal load transport. The distance from Johannesburg to *Doornhoek 2 PV Facility* is approximately 185 km, along the N12.

It should be noted that only 1-2 abnormal load trips per site is expected for *Doornhoek 2 PV Facility*. Abnormal load transportation is therefore considered to be isolated and would have a negligible impact on traffic over the construction phase of the project. As indicated in *Section 3.2.4 above*, the abnormal load will still necessitate the application of an abnormal load permit for each province that the route traverses.

The route from Johannesburg to the site traverses the *Gauteng Province* and the *North West Province*. In addition to the ports of entry, abnormal haulage is also expected from Johannesburg. The route is indicated in Figure 3.3.

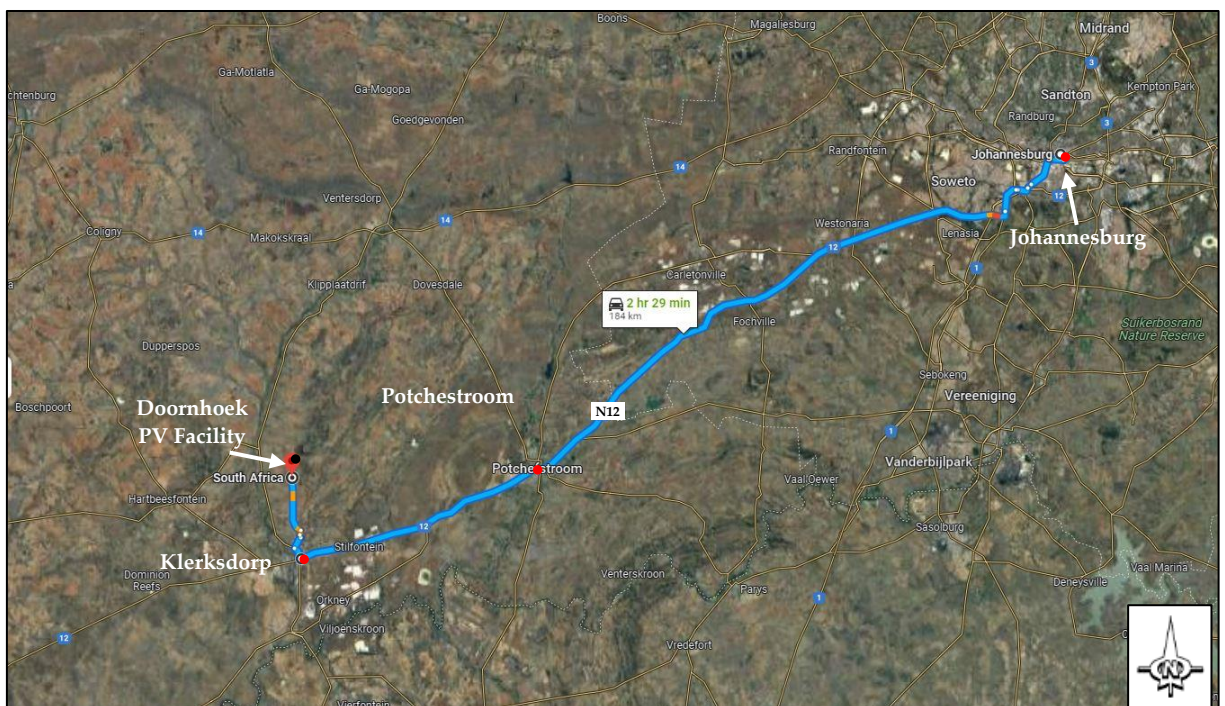

Figure 3.3: Transportation route (Johannesburg to Doornhoek PV Facility)

The route description (*Source: Google Maps*) is as follows:

- Drive onto Francois Oberholzer Freeway/M2 in Village Main, Johannesburg South from Von Wielligh St and Dennis Rd;
- Follow N12 to Chris Hani Rd/Jan Van Riebeeck Rd/R30 in Klerksdorp Central, Klerksdorp. Exit from N12 (166 km);
- Drive to your destination (16.1 km) in the *City of Matlosana*.

This route is also appropriate for haulage of normal heavy loads from Gauteng. It should be noted that this is a general route description highlighting the N12 regional route, as location of suppliers is not yet established.

3.5 HAULAGE OF OTHER PLANT, CONSTRUCTION MATERIAL AND EQUIPMENT

In addition to transporting the specialised equipment, the normal civil engineering construction materials, plant and equipment will need to be transported to the site (e.g. sand, stone, cement, gravel, water, compaction equipment, concrete mixers, etc.). Other components, such as electrical cables, pylons and substation transformers, will also be transported to site during construction. The transport of these items will generally be conducted with normal heavy loads vehicles, except for the transformers as previously discussed.

Cement will be sourced from local manufacturers in nearby towns. All other civil construction materials, needed for concrete and wearing course, will be obtained from a local licensed quarry off-site. These trips can be classified as local trips as vehicles will not be travelling over a very long distance.

3.6 TRANSPORT OF CONSTRUCTION PERSONNEL

It is anticipated that construction personnel and labour would originate from neighbouring towns. These trips can be classified as local trips as vehicles will not be travelling over a very long distance.

3.7 ROUTE CLEARANCE

The vehicles used to transport the photovoltaic equipment are standard container trucks. The transformers will be transported as abnormal loads. At this stage of the project, the routes and areas for clearance cannot be established and should be confirmed with the freight carriers in later stage of the project. However, no new obstacles (e.g. low overhead services, cattle grids, narrow bridges, etc.) are expected for abnormal load haulage as similar projects in close proximity to the proposed development may have previously cleared areas along transport routes.

3.8 SUMMARY

It is anticipated that the solar panel technology and larger electrical components would be imported and arrive via ship at marine ports of entry. Haulage routes from two ports of entry, namely Saldanha Bay Harbour and Durban Harbour, were identified and assessed. The final decision on the selected route would be based on a combination of cost, distance and road condition at the time of transport.

Minimal abnormal load trips for transformers would be required for the project. It is anticipated that this would require haulage from the port of entry to the manufacturing site

(possibly Johannesburg) before being hauled to site. These are considered to induce minimal impact on traffic over the course of the construction period but will require the necessary permits for abnormal load transport.

The materials required for site, including the solar panel technology would require transport by normal heavy vehicle loads. As discussed in Section 2.4 above, it is proposed that the access roads in close proximity to the site be investigated for rehabilitation prior to construction and be maintained during construction in order to mitigate against the possibility of damaged goods due to poor road infrastructure.

CHAPTER 4 BACKGROUND TRAFFIC VOLUMES

4.1 OVERVIEW

Background traffic volumes were determined for the study network near the site, as well as along the transportation routes. These traffic volumes were acquired in order to determine what the existing traffic conditions are like in the absence of the proposed solar power plant.

Various traffic recording stations on major roadways, along transportation routes, were identified and are provided in the sub-chapters below. The traffic count data was mainly sourced from temporary counting stations, for which approximately one week of traffic data was recorded. Where available, permanent counting stations provided historic data over multiple years, indicating trends in traffic growth at those locations.

It must be noted that the traffic data was only recorded up until December 2019. The period for traffic assessment was selected as four years as it is estimated that approvals, planning and design phases would take 2-3 years and the construction phase, which would generate the highest number of trips for the project, would occur during year 4. Therefore, the existing traffic volumes for the years 2020 to 2022 for current estimated traffic volumes and to 2026 for the four-year horizon for traffic assessment were predicted as described below.

4.2 REGIONAL TRAFFIC

4.2.1 Alternative 1: Port of Durban to Doornhoek 2 PV Facility

The following traffic recording stations were identified along the Durban route:

Table 4.1: Traffic recording stations (Port of Durban route)

SITE IDENTIFIER	LOCATION	ROUTE	NO. OF LANES	2019 AVERAGE DAILY TRAFFIC (ADT)	2019 AVERAGE DAILY TRUCK TRAFFIC (ADTT) (% OF ADT)
1990 - Estcourt I/C	Southern side of Giants Castle I/C	N3	6	17611	7487 (42.5%)
533 - Bethlehem East	Between Kestell and Bethlehem	N5	2	5020	1393 (27.7%)
875 - Bethlehem	5 km west of Bethlehem	N5	2	4330	1088 (25.1%)

From the table above it can be seen that heavy vehicles contribute between 25% and 43% to the total traffic volumes along the Durban transportation route.

4.2.2 Alternative 2: Port of Saldanha to Doornhoek 2 PV Facility

The following traffic recording stations were identified along the Saldanha route:

Table 4.2: Traffic recording stations (Port of Saldanha route)

SITE IDENTIFIER	LOCATION	ROUTE	NO. OF LANES	2019 AVERAGE DAILY TRAFFIC (ADT)	2019 AVERAGE DAILY TRUCK TRAFFIC (ADTT) (% OF ADT)
1337 - Touwsriver West	2km West of N1 Touwsriver I/S	R46	2	689	194 (28.2%)
5066 - PGWC CeresKaroo	Between R46 & Calvinia	R355	2	328	56 (17.1%)

From the table above it can be seen that heavy vehicles contribute between 17% and 28% to the total traffic volumes along the Saldanha transportation route.

4.3 LOCAL TRAFFIC

The following traffic station data was acquired from SANRAL for the main routes in the region of Klerksdorp. These sites were short-term counts that were recorded in 2019.

Table 4.3: Traffic recording stations near Klerksdorp

SITE IDENTIFIER	LOCATION	ROUTE	NO. OF LANES	2019 AVERAGE DAILY TRAFFIC (ADT)	2019 AVERAGE DAILY TRUCK TRAFFIC (ADTT) (% OF ADT)
19847 - Regina	Between Klerksdorp and Wolmaransstad	N12	4	14809	1361 (9.20%)
19848 - Flamwood SB	Between Klerksdorp and Stilfontein	N12	3	9632	1034 (10.70%)
19849 - Flamwood NB	Between Klerksdorp and Stilfontein	N12	2	9437	1073 (11.40%)
19220 - Lapfontein	Between Ventersdorp and Klerksdorp	R30	2	2833	347 (12.20%)

The surveyed traffic data above has been used to estimate current day 2022 average daily traffic and for the 4-year horizon background daily traffic.

4.4 CAPACITY ANALYSIS

The following capacity analysis considers only the background traffic, without the additional traffic due to the development.

The *TRH 17* document was consulted in order to determine whether the capacities of the above-mentioned roadways would be exceeded within the near future. The capacity analysis results are indicated in Table 4.4 below.

The estimated background traffic for the current year (2022) and for the horizon year (2026) was determined according to the available data. The historic data for the regional traffic was used with a trendline analysis to estimate the background traffic for the current year and horizon year. The local traffic was escalated with 1.0% per annum to estimate the background traffic for the same years. The predicted traffic volumes for the year 2026 is provided in the table below. See *Appendix A* for graphical illustration.

Table 4.4: Capacity analysis (background traffic)

SITE IDENTIFIER	ROUTE	2022 ADT (vpd)	2022 LEVEL OF SERVICE (LOS)	2026 ADT (vpd)	2026 LEVEL OF SERVICE (LOS)
REGIONAL TRAFFIC – DURBAN ROUTE					
1990	N3	17105	B	17105	B
533	N5	5153	C	5208	C
875	N5	4663	C	5045	C
REGIONAL TRAFFIC – SALDANHA ROUTE					
1337	R46	714	A	755	A
5066	R355	329	A	396	A
LOCAL TRAFFIC					
19847	N12	15258	B	15877	B
19848	N12	9924	B*	10327	B*
19849	N12	9723		10118	
19220	R30	2919	C	3037	C

*The northbound and southbound traffic for the two counting stations (19848, 19849) have been evaluated as a combined 4-lane freeway

The section on the N3 (SITE ID 1990) consists of three lanes in each direction. LOS assessed as 4-lane freeway. Trendline indicated negative growth. Zero change in traffic was therefore selected instead of decreased traffic.

From the table above it is concluded that the capacities of the assessed roadways are not degraded or exceeded in terms of average daily traffic volumes due to background traffic within the assessment period.

CHAPTER 5 TRIP GENERATION

5.1 OVERVIEW

The proposed *Doornhoek 2 PV Facility* will generate additional traffic on the surrounding road network in three (3) distinct phases, namely: construction, operational and decommissioning. It must be noted that these three phases will generate traffic consecutively and not simultaneously, and therefore will be considered separately from each other.

5.2 CONSTRUCTION PHASE

Trips generated during the construction phase will primarily comprise of transporting equipment, energy facility components, personnel, construction and other facility materials. These trips will comprise of normal, medium and heavy vehicles.

The following assumptions were made in order to calculate trips generated during the construction phase of the project:

- It is estimated that the construction period will last approximately twelve (12) months, with twenty-two (22) working days per month. This results in approximately 400 working days over the construction period.
- The *Doornhoek 2 PV Facility* will most likely be constructed from components that will be shipped to South Africa via the Port of Durban. These components will be transported to site via road transport using medium and heavy vehicles.
 - The solar energy facility will generate approximately up to 50 MW electrical power.
 - Approximately 113 000 PV modules of approximately 300 – 550 W each will be delivered to site. Approximately 660 of these 300 – 550 W units can fit into one (1) container (30 units per pallet; 22 pallets per container). This results in approximately 180 container loads in total being delivered to site.
- Other plant, materials and equipment will be sourced from the nearest towns. An average of 200 -300 trips per 7MW is assumed. For this site, this has been assumed to be 40 trips per MW. This results in approximately 2 100 trips over the 12-month construction period.

Another contributor to trips generated during the construction phase will be daily commuters/workers. The following assumptions were made in this regard:

- The construction labour force will be mostly local.
- It is assumed that approximately 350 staff members/workers will be on site.
 - Based on the composition it is assumed that 10% of the staff members will make use of private or company vehicles (cars and LDVs). These staff members will travel from their permanent or temporary residences to site on a daily basis.
 - It is assumed that the remainder of the staff members (90%) will be transported to site with 15-seater minibus-taxis. The quantities of these vehicles will fluctuate and will depend on the number of labourers, costs, routes and operating hours.

The table below summarises the estimated total trips that will be generated during the construction phase of the project:

Table 5.1: Trip generation (construction phase)

TRANSPORT TYPE	SITE	PARAMETER	AVERAGE DAILY TRAFFIC	MONTHLY TRAFFIC	TOTAL TRIPS (12mo.)
Normal heavy load (solar panels)	Doornhoek 1	660 panels per container	1	22	180
Normal heavy load (construction materials)	Doornhoek 1	40 trips/MW	8	176	2 100
LDVs and cars (Staff)	Doornhoek 1	350 staff	56	1 232	14 800
TOTAL TRIPS FOR CONSTRUCTION PERIOD			69	1 518	17 080

It can be seen from the table above that the construction phase of *Doornhoek 2 PV Facility* will generate approximately 17 080 trips over the twelve (12) month period.

5.3 OPERATIONAL PHASE

The following assumptions were made with regards to the trip generation during the operational phase of the solar power plant:

- The *Doornhoek 2 PV Facility* will be in operation between twenty (20) and thirty (30) years.
- The solar energy facility will be in operation seven (7) days a week. Therefore, personnel will operate according to shifts.
- The operational team will consist of approximately fifty (50) people:

The traffic impact during the operational phase will therefore be insignificant, as approximately only fifty (50) people will work at the solar power plant.

5.4 DECOMMISSIONING PHASE

The decommissioning phase will start at the end of the Doornhoek 1 SEF lifetime (20 – 30 years) and will last approximately six (6) months, involving a team of fifty (50) workers. As per the operational phase, the traffic impact will be insignificant.

CHAPTER 6 TRAFFIC IMPACT ASSESSMENT

6.1 OVERVIEW

The expected effects of traffic that would be generated by the proposed *Doornhoek 2 PV Facility* analysed as follows:

- The background traffic volumes were determined for the study network near the site, as well as along the transportation routes (Refer to *Chapter 4: Background Traffic Volumes*).
- The existing traffic volumes for the years 2020 to 2026 were predicted and were based on trendline analyses or annual escalation as indicated.
- Construction phase traffic (site-generated trips) were estimated for the proposed solar power plant.
- The construction phase traffic is then added to the 2026 background traffic volumes to determine the total traffic conditions with the solar power plant completed.

The sub-chapters below provide the impact the development of the solar power plant will have on the transportation routes and local traffic respectively.

6.2 ASSESSMENT OF IMPACTS ON REGIONAL TRANSPORTATION ROUTES

The trips generated by this development were evaluated in relation to the quantum of trips needed to change the Level of Service (LOS) on a portion of the rural highway and the ultimate capacity of two-lane highways.

As seen in Chapter 5, the traffic impact of the delivery and construction trips on the Saldanha and Durban routes are minimal, with average additional traffic of 1 trip per day from the ports of entry over the duration of the project, and 8 trips per day for normal heavy vehicles for construction materials.

These construction trips will be insignificant when compared to the Average Daily Traffic (ADT) and will not affect the existing Level of Service (LOS). It can therefore be concluded that, in terms of estimated traffic volumes, no mitigation measures will be necessary.

6.3 ASSESSMENT OF IMPACTS ON LOCAL TRAFFIC

The capacity of a two-lane highway is 3200 vehicles per hour (vph), under ideal conditions, *HCM 6th Edition Chapter 15: Two Lane Highways*. The ideal conditions referred to is the absence of any restrictive geometry, traffic, or environmental factors.

From traffic count data and Level of Service calculations, the N12 and R30 around Klerksdorp have sufficient spare capacity to accommodate the additional traffic due to the development. The table below indicate the effect of the commuter trips on the N12 and R30.

Table 6.1: Traffic impact on N12 and R30 (commuter trips)

SITE ID	ROUTE	2026 EST. ADT ON ROUTE (vpd)	CONSTRUCTION TRIPS (vpd)	TOTAL TRIPS (vpd)	LOS
19847	N12	15 887	65	15 952	B
19848	N12	10 327	65	10 392	B
19849	N12	10 118	65	10 183	B
19220	R30	3 037	65	3 102	C

It can be concluded from the table above that the estimated additional traffic generated by the development, when travelling to/from the *Doornhoek 2 PV Facility*, can be accommodated on the existing road network. Mitigation measures would not be required to due to the increased traffic.

From a traffic point of view, it was found that the total daily construction traffic will be low and will not significantly influence the surrounding communities.

CHAPTER 7 IMPACT ASSESSMENT SUMMARY

7.1 OVERVIEW

The impact of the proposed development has been assessed in terms of traffic as shown below. For the purpose of the environmental impact reporting requirements of the 2014 EIA Regulations, the traffic impact of the proposed development is presented in terms of the assessment methodology described in *Appendix C* of this report.

7.2 IMPACT ASSESSMENT – CONSTRUCTION PHASE REGIONAL TRAFFIC

In terms of traffic and transport, the impact that the proposed development has is as follows:

Nature: <u>Increased traffic on regional haulage routes:</u>		
The haulage routes for light and heavy vehicles include regional routes that would be impacted by the construction of the development. The delivery of imported construction materials to site would likely originate from Johannesburg and Durban Harbour, as discussed in the preceding chapter, slightly increasing the average daily traffic of the routes used over the construction period.		
	Without mitigation	With mitigation
Extent	Regional (3)	Regional (3)
Duration	Short-term (2)	Short-term (2)
Magnitude	Small (1)	Small (1)
Probability	Probable (3)	Probable (3)
Significance	Low (18)	Low (18)
Status (positive or negative)	Neutral	Neutral
Reversibility	Completely	Completely
Irreplaceable loss of resources?	No loss	No loss
Can impacts be mitigated?	Yes, to a limited extent. The benefit of mitigation would not be viable for the project.	
Mitigation: The impact of the increased traffic on regional routes can be mitigated by staggering trips and scheduling so that peak hour traffic in local towns is not impacted by construction traffic.		
Residual Impacts: The magnitude of the increased traffic on regional routes is too small to solely attribute any negative impact on routes to the development's construction traffic.		

7.3 IMPACT ASSESSMENT – CONSTRUCTION PHASE LOCAL TRAFFIC

Nature: <u>Increased traffic on local routes:</u>		
The increased traffic on the local routes may add to local congestion in the town. It should be noted that this would only be noticeable if construction traffic passes through the local town during peak periods. In general, only approximately 15% of daily traffic may be attributed to peak hour volumes.		
	Without mitigation	With mitigation
Extent	Local (2)	Local (2)
Duration	Short-term (2)	Short-term (2)
Magnitude	Small (1)	Small (1)
Probability	Probable (3)	Probable (3)
Significance	Low (15)	Low (15)
Status (positive or negative)	Neutral	Neutral
Reversibility	Completely	Completely
Irreplaceable loss of resources?	No loss	No loss
Can impacts be mitigated?	Yes, the increased traffic can be mitigated to a limited extent. Mitigation in terms of road condition need to be addressed as part of the maintenance during construction.	
Mitigation: The impact of the increased traffic on local routes can be mitigated by staggering trips and scheduling so that peak hour traffic in local towns is not impacted by construction traffic.		
Residual Impacts: The magnitude of the increased traffic on local routes are minimal. Local traffic will mainly be impacted during peak hours.		

7.4 IMPACT ASSESSMENT – SITE ROADS INFRASTRUCTURE

Nature: <u>Construction and maintenance of gravel roads in vicinity of the site:</u>		
<p>The construction traffic accessing the site would be traveling along roads that are proposed to be unsurfaced for the development. The movement of heavy vehicles along the gravel roads, especially close to the boundaries of the site, may cause excessive dust in the area. Deterioration of gravel roads may also occur after wet seasons, leading to poor road conditions for transportation on site.</p>		
	Without mitigation	With mitigation
Extent	Local (1)	Local (1)
Duration	Short-term (2)	Short-term (2)
Magnitude	Small (1)	Small (1)
Probability	Probable (3)	Probable (3)
Significance	Low (12)	Low (12)
Status (positive or negative)	Neutral	Neutral
Reversibility	Completely	Completely
Irreplaceable loss of resources?	No loss	No loss
Can impacts be mitigated?	Yes.	
Mitigation:		
<p>Maintenance to lower order roads can be incorporated into the schedule, especially the maintenance of the road accessing the site. The site access road would require construction at the start of the construction project, in order to safely transport the sensitive cargo through the site. A gravel roads maintenance programme for the gravel roads on site is recommended.</p>		
Residual Impacts:		
<p>A gravel roads maintenance programme will need to be developed and adhered to for the construction as well as operational phase of the development. Maintenance of the roads on the site need to be enforced to ensure deterioration is controlled.</p>		

7.5 IMPACT ASSESSMENT – OPERATIONAL PHASE TRAFFIC

Nature: <u>Increased traffic during operational phase:</u>		
The current traffic will increase slightly due to the employees on site during the operational phase. The traffic generated during this phase will be minimal and will not have any impact on the surrounding road network.		
	Without mitigation	With mitigation
Extent	Local (1)	Local (1)
Duration	Long-term (4)	Long-term (4)
Magnitude	Small (1)	Small (1)
Probability	Probable (3)	Probable (3)
Significance	Low (18)	Low (18)
Status (positive or negative)	Neutral	Neutral
Reversibility	Completely	Completely
Irreplaceable loss of resources?	No loss	No loss
Can impacts be mitigated?	Yes, to a limited extent	
Mitigation:		
The impact of the increased traffic during the operational phase is negligible due to the expected number of employees. The shift work provides a mitigation and reduces the expected number of employees, especially during peak hours.		
Residual Impacts:		
The magnitude of the increased traffic is relatively small and is not likely to change during the operational phase of the development. These trips will become part of the network trips due to the development.		

CHAPTER 8 CUMULATIVE IMPACT ASSESSMENT

8.1 OVERVIEW

The cumulative impact of the proposed development has been assessed in two phases. It has been assessed, firstly, in terms of the cumulative impact of the implementation of the *Doornhoek 2 PV Facility* together with the neighbouring *Doornhoek 1 PV Facility* and then, secondly, in terms of the cumulative impact of the *Doornhoek PV Cluster* together with similar solar farm developments within a 30 km radius.

8.2 CUMULATIVE IMPACT – DOORNHOEK PV CLUSTER

Doornhoek 1 PV Facility and *Doornhoek 2 PV facility* are two proposed developments that are being planned concurrently and are adjacent to each other. The concurrent construction of these facilities would increase the trip generation to the cumulative trip generation for the combined sites, as all trips would require the use of the same access road.

Nature: <u>Increased traffic on local routes:</u>		
The increased traffic on the local routes may add to local congestion in the town. The estimated total average daily traffic generation for <i>Doornhoek 1</i> is 69 vehicles per day and 65 vehicles per day for <i>Doornhoek 2</i> . The resulting cumulative 134 vehicles indicates that the average daily local traffic would need to be accommodated at the site access and public road adjacent to the site. As per the individual impact assessment, in general, only approximately 15% of daily traffic could be attributed to peak hour volumes.		
The increased heavy traffic on local routes may also contribute to the deterioration of lower order roads over time.		
	Without mitigation	With mitigation
<i>Extent</i>	Local (2)	Local (2)
<i>Duration</i>	Short-term (2)	Short-term (2)
<i>Magnitude</i>	Small (1)	Small (1)
<i>Probability</i>	Probable (3)	Probable (3)
<i>Significance</i>	Low (15)	Low (15)
<i>Status (positive or negative)</i>	Neutral	Neutral
<i>Reversibility</i>	Completely	Completely
<i>Irreplaceable loss of resources?</i>	No loss	No loss
<i>Can impacts be mitigated?</i>	Yes, the increased traffic can be mitigated to a limited extent. Mitigation in terms of road condition need to be addressed as part of the maintenance during construction.	
Mitigation:		

The impact of the increased traffic on local routes can be mitigated by staggering trips and scheduling so that peak hour traffic in local towns is not impacted by construction traffic.

Maintenance to lower order roads can be incorporated into the schedule, especially the maintenance of the road accessing the site. The site access road would require construction at the start of the construction project, in order to safely transport the sensitive cargo through the site.

Residual Impacts:

The magnitude of the increased traffic on local routes are minimal. Local traffic will mainly be impacted during peak hours.

Maintenance of the roads on the site need to be enforced to ensure deterioration is controlled.

8.3 CUMULATIVE IMPACT – SOLAR FARM DEVELOPMENT IN 30km RADIUS

Table 8.1 below provides a summary of other renewable energy projects that may be constructed during the same period as the *Doornhoek 2 PV Facility*. While this is unlikely, all these projects are included in the cumulative trip generation and subsequently the cumulative impact assessment.

The expected regional trip generation presented below has been based on the proportional number of PV panels requiring transport from a port of entry, in comparison to the design MW capacity of Doornhoek.

Table 8.1: Additional solar power projects (within 30 km radius from study area)

NO.	PROJECT NAME	DISTANCE FROM STUDY AREA (km)	CAPACITY (MW)	EXPECTED TOTAL REGIONAL TRIPS
1	Doornhoek 1 PV	-	115 MW	400
2	Buffels Solar 2	26 km	100 MW	350
3	Buffels Solar 1	25 km	75 MW	260
4	Witkop Solar PV II	27 km	61 MW	220
5	Kabi Vaalkop PV	23 km	75 MW	260
TOTAL REGIONAL TRIPS OVER CONSTRUCTION PERIOD				1 490

It can be assumed that only the regional routes could be assessed cumulatively, as the local routes would differ for each site's primary study area. The above total trips results in an additional 3-4 daily trips over a 400-day construction period. This is deemed negligible and would not have an impact on regional routes during a scenario of concurrent construction.

The cumulative impact assessment on the regional routes, assessed according to the assessment methodology is presented as follows:

Nature: <u>Increased traffic on regional haulage routes:</u>		
The haulage routes for heavy vehicles for the shipment of solar panels and major components include regional routes that would be impacted by the simultaneous construction of similar projects within 30 km of the development. This cumulative scenario is expected to slightly increase the average daily traffic of the routes used over the construction period.		
	Without mitigation	With mitigation
Extent	Regional (3)	Regional (3)
Duration	Short-term (2)	Short-term (2)
Magnitude	Small (0)	Small (0)
Probability	Very improbable (1)	Very improbable (1)
Significance	Low (5)	Low (5)
Status (positive or negative)	Neutral	Neutral
Reversibility	Completely	Completely
Irreplaceable loss of resources?	No loss	No loss
Can impacts be mitigated?	Yes, to a limited extent.	
Mitigation:		
The cumulative impact would not require mitigation, as the regional routes would still operate at an acceptable level of service. Should mitigation be required, the staggering of trips would be encouraged to avoid platooning of heavy vehicles along regional routes. This would, however, require a degree of co-ordination between the various developments.		
Residual Impacts:		
The magnitude of the increased traffic on regional routes is too small to solely attribute any negative impact on routes to the development's construction traffic. The duration of the impact is also short-term and is reversed after the construction period.		

CHAPTER 9 SUMMARY AND CONCLUSION

9.1 SUMMARY

The proposed *Doornhoek 2 PV Facility* is located on a site approximately 11 km north of Klerksdorp in the North West Province. It will comprise several arrays of PV panels and associated infrastructure and will have a contracted capacity of up to 50 MW. The proposed *Doornhoek 2 PV Facility* will be located on Portion 18 of the Farm Doornhoek No. 372-IP and is proposed to cover approximately 80 ha. The infrastructure will include the PV grid with inverters and transformers, BESS, operations and maintenance buildings, internal site roads and electrical grid connection infrastructure.

The site for this development is located off a two-lane surfaced local district road, which provides multiple farms in the area with access to the greater road network. This access road links to District Road in Klerksdorp, to the south of the site. The major routes in the immediate vicinity of the site are the R30 to the west of the site, N12 to the south of the site, which have been used in the traffic impact evaluation.

For the traffic assessment, regional and local transport routes were investigated:

- For regional routes, haulage routes from various ports of entry (Durban Harbour and Saldanha Bay Harbour) were investigated. The regional routes were mainly national routes, with the N3 and N5 considered from Durban Harbour and R45 and R46 considered from Saldanha Bay Harbour. A regional route from Johannesburg has also been assessed and presented for the haulage of major electrical components.
- For the assessment of local routes, routes close to the site were assessed for impact of local trips on the local network.
- The existing traffic volumes on the transportation routes were sourced and used to calculate the current background traffic, the expected background traffic during construction and, thereby, the Level of Service. The number of trips generated from the construction period were estimated and the impact of these additional trips on the regional and local transport routes were also investigated.

An additional up to 115 MW PV facility (*Doornhoek 1 PV Facility*) is concurrently being considered on the same property and is being assessed through a separate Basic Assessment (BA) process. The cumulative impact of the concurrent development of these two facilities was assessed in terms of traffic.

Also, as part of the cumulative impact assessment, similar solar farm projects within a radius of 30 km were also assessed and the impact assessment reported in terms of the assessment methodology required.

9.2 CONCLUSIONS

The following conclusions were drawn from the study:

- The major traffic impact occurs during the construction phase of the project. The impact of the construction trip generation, on the predicted 2026 (estimated time of construction) traffic volumes on the local and the regional transportation routes are expected to be low. No mitigation measures for these routes will be necessary.
- The photovoltaic (PV) components will be delivered to site from two possible ports, either from Saldanha Bay Harbour over a distance of 1 340 km or from Durban Harbour over a distance of 665 km. The regional routes indicated in the analysis would need to be confirmed by freight carriers as suitable for the sensitive normal loads. The final decision on the selected route would be based on a combination of cost, distance and road condition at the time of transport.
- Transformer and substation components will be transported via abnormal loads. An abnormal load will necessitate an application to the *Department of Transport and Public Works* for a permit. A permit is required for each province that the transportation route traverses. Only 1-2 abnormal load trips per site is expected for *Doornhoek 2 PV Facility*. Abnormal load transportation is therefore considered to be isolated and would have a negligible impact on traffic over the construction phase of the project.
- In terms of impact on roads infrastructure:
 - It is proposed that the access roads in close proximity to the site be investigated for rehabilitation prior to construction and be maintained during construction in order to mitigate against the possibility of damaged goods due to poor road infrastructure.
 - The formalisation of the site access point, will likely be a requirement as part of the wayleave approval of the local and provincial roads authorities.
 - Adequate traffic accommodation signage must be erected and maintained on either side of the access throughout the construction period of the project.
 - While no construction of the PV facility occurs within the servitude, the construction and provision of internal roads that cross the servitude need to be according to Eskom wayleave requirements.
- In terms of impact on traffic:
 - The regional construction trips will be insignificant when compared to the Average Daily Traffic (ADT) and will not affect the existing Level of Service (LOS). It can therefore be concluded that, in terms of estimated traffic volumes, no mitigation measures will be necessary. Mitigation measures, such as staggered trips and reduced peak time travel are proposed if needed.
- In terms of cumulative impact:
 - The concurrent construction of *Doornhoek 1 PV Facility* and *Doornhoek 2 PV Facility* is considered to have a low impact. Mitigation measures that may be considered include the staggering of trips at the site and the implementation of a roads maintenance programme.

- The unlikely concurrent construction of four other solar farms in a 30 km radius of the site has also been considered. Only the regional trips were considered as it would be possible that the same port of entry would be considered for these sites. The local trips were not considered as these neighbouring solar farm developments, while in close proximity to each other, might not share the same primary study area. This impact is considered to be low.

The development of the *Doornhoek 2 PV Facility* on Portion 18 of the Farm Doornhoek No. 372-IP near Klerksdorp in the North West Province can therefore be supported from a traffic engineering perspective.

APPENDIX A

BACKGROUND TRAFFIC VOLUMES

Traffic Estimation

LOS based on 4-lane ADT

Lanes		1990 - ESTCOURT IC (N3)						
YEAR	AVERAGE DAILY TRAFFIC (ADT)			AVERAGE DAILY TRUCK TRAFFIC (ADTT)			TOTAL	
	TO SPRINGBOK	TO CAPE TOWN	TOTAL	TO SPRINGBOK	TO CAPE TOWN	TOTAL		
2015								
2016	8933	9178	18111	3351	3315	6666		
2017	9022	8911	17933	3375	3394	6769		
2018								
2019	8847	8764	17611	3590	3897	7487	42.5%	
2020	8544	8893	17437	3794	3949	7742		
2021	8463	8808	17271	3934	4094	8028		
2022	8381	8724	17105	4074	4240	8314		
2023	8300	8639	16939	4214	4386	8600		
2024	8219	8554	16773	4354	4532	8886		
2025	8138	8470	16608	4494	4677	9172		
2026	8056	8385	16442	4634	4823	9457		

Southern side of Giants Castle I/C

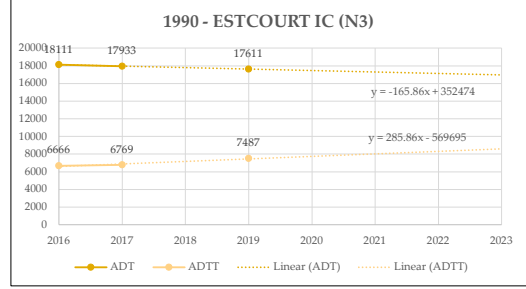

Lanes		533 - BETHLEHEM EAST (N5)						
YEAR	AVERAGE DAILY TRAFFIC (ADT)			AVERAGE DAILY TRUCK TRAFFIC (ADTT)			TOTAL	
	TO KESTELL	TO BETHLEHEM	TOTAL	TO KESTELL	TO BETHLEHEM	TOTAL		
2015	2467	2484	4951	642	625	1267		
2016	2502	2542	5044	612	627	1239		
2017	2550	2572	5122	652	649	1301		
2018	2542	2545	5087	666	658	1324		
2019	2505	2515	5020	701	692	1393	27.7%	
2020	2540	2559	5099	705	701	1406		
2021	2549	2568	5117	722	718	1440		
2022	2558	2577	5135	739	734	1473		
2023	2567	2586	5153	756	751	1507		
2024	2576	2595	5171	773	768	1541		
2025	2585	2604	5190	790	785	1575		
2026	2594	2613	5208	807	802	1608		

Between Kestell and Bethlehem

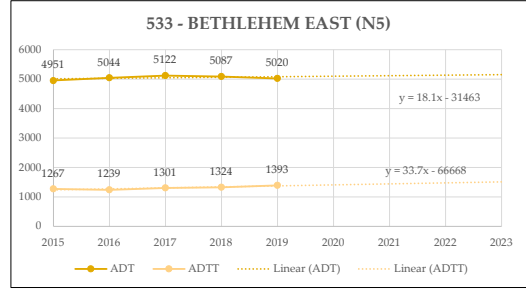

Lanes		875 - BETHLEHEM (N5)						
YEAR	AVERAGE DAILY TRAFFIC (ADT)			AVERAGE DAILY TRUCK TRAFFIC (ADTT)			TOTAL	
	TO HARRISMITH	TO WINBURG	TOTAL	TO HARRISMITH	TO WINBURG	TOTAL		
2015	1907	2015	3922	402	440	842		
2016	2033	2108	4141	453	476	929		
2017	2103	2151	4254	458	487	945		
2018	2121	2159	4280	500	520	1020		
2019	2144	2186	4330	532	556	1088	25.1%	
2020	2191	2281	4472	559	581	1140		
2021	2238	2329	4568	587	611	1198		
2022	2285	2378	4663	616	641	1257		
2023	2332	2427	4759	644	671	1315		
2024	2378	2476	4854	673	700	1373		
2025	2425	2524	4950	701	730	1432		
2026	2472	2573	5045	730	760	1490		

5 km west of Bethlehem

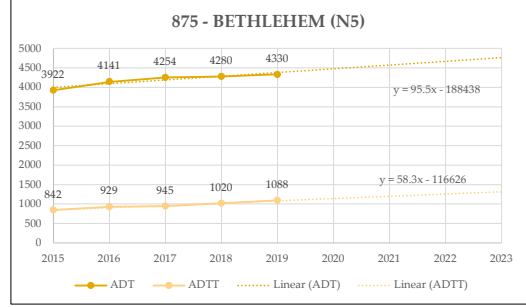

Traffic Estimation

1337 - TOUWS RIVER WEST			
Lanes	YEAR	ADT	ADTT
2	2015	634	183
LOS	2016	665	175
	2017	661	186
	2018	659	174
	2019	689	194
	2020	693	189
	2021	703	191
A	2022	714	193
	2023	724	195
	2024	735	197
	2025	745	199
	2026	755	201
A	2027	766	203

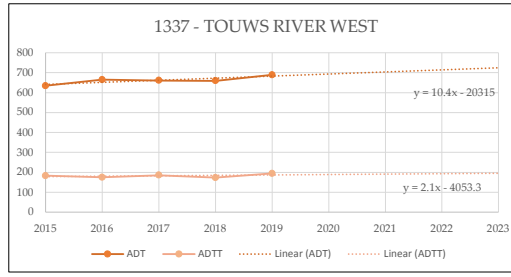

5066 - PGWC CERES KAROO			
Lanes	YEAR	ADT	ADTT
2	2015	242	46
LOS	2016	227	25
	2017	205	18
	2018	223	25
	2019	328	56
	2020	295	40
	2021	312	42
A	2022	329	44
	2023	345	46
	2024	362	48
	2025	379	50
	2026	396	52
A	2027	413	54

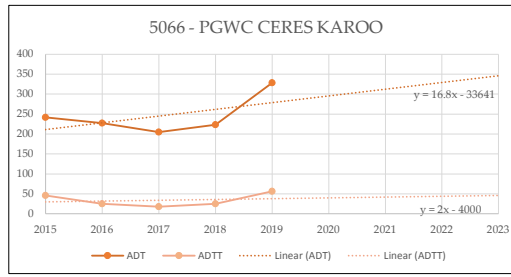

APPENDIX B

TYPICAL ACCESS GEOMETRY

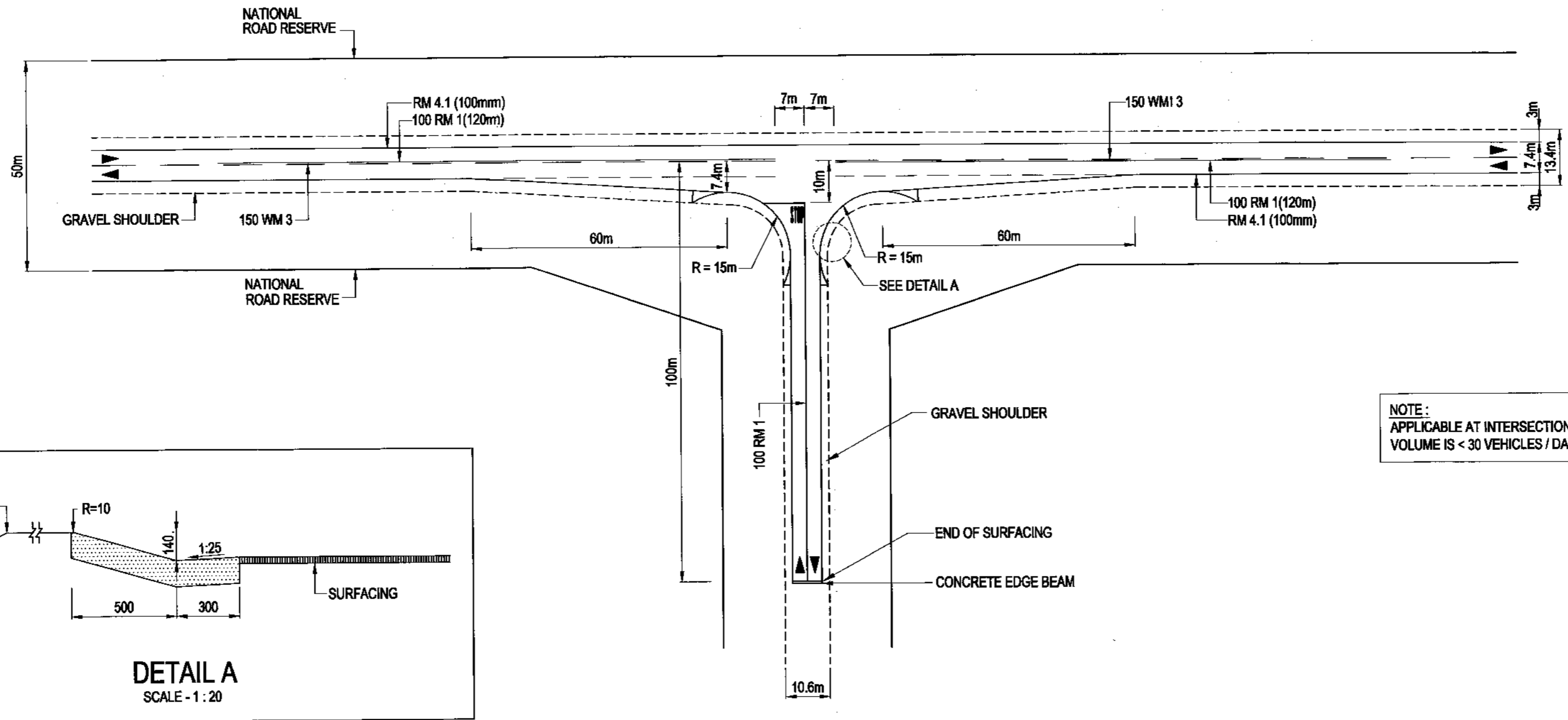

ROAD MARKING LEGEND	
RM 1	= NO OVERTAKING LINE
RM 4.1	= LEFT EDGE LINE
WM 3	= DIVIDING LINE

NOTE:
APPLICABLE AT INTERSECTIONS WHERE THE RIGHT TURNING VOLUME IS < 30 VEHICLES / DAY.

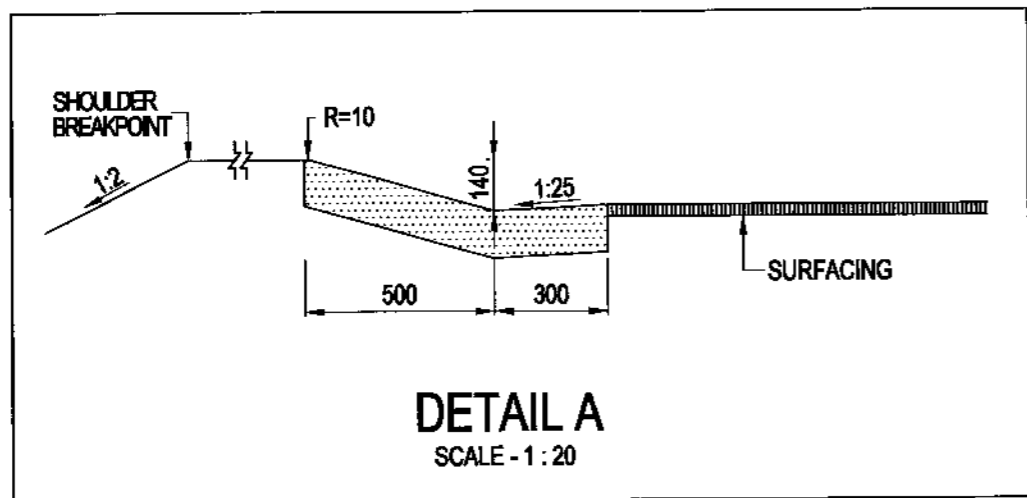

DESIGN SPEED (THROUGH ROAD) (km/h)	SIGHT DISTANCE (D) (m)
50	150
60	180
70	210
80	240
90	270
100	300
110	330
120	360

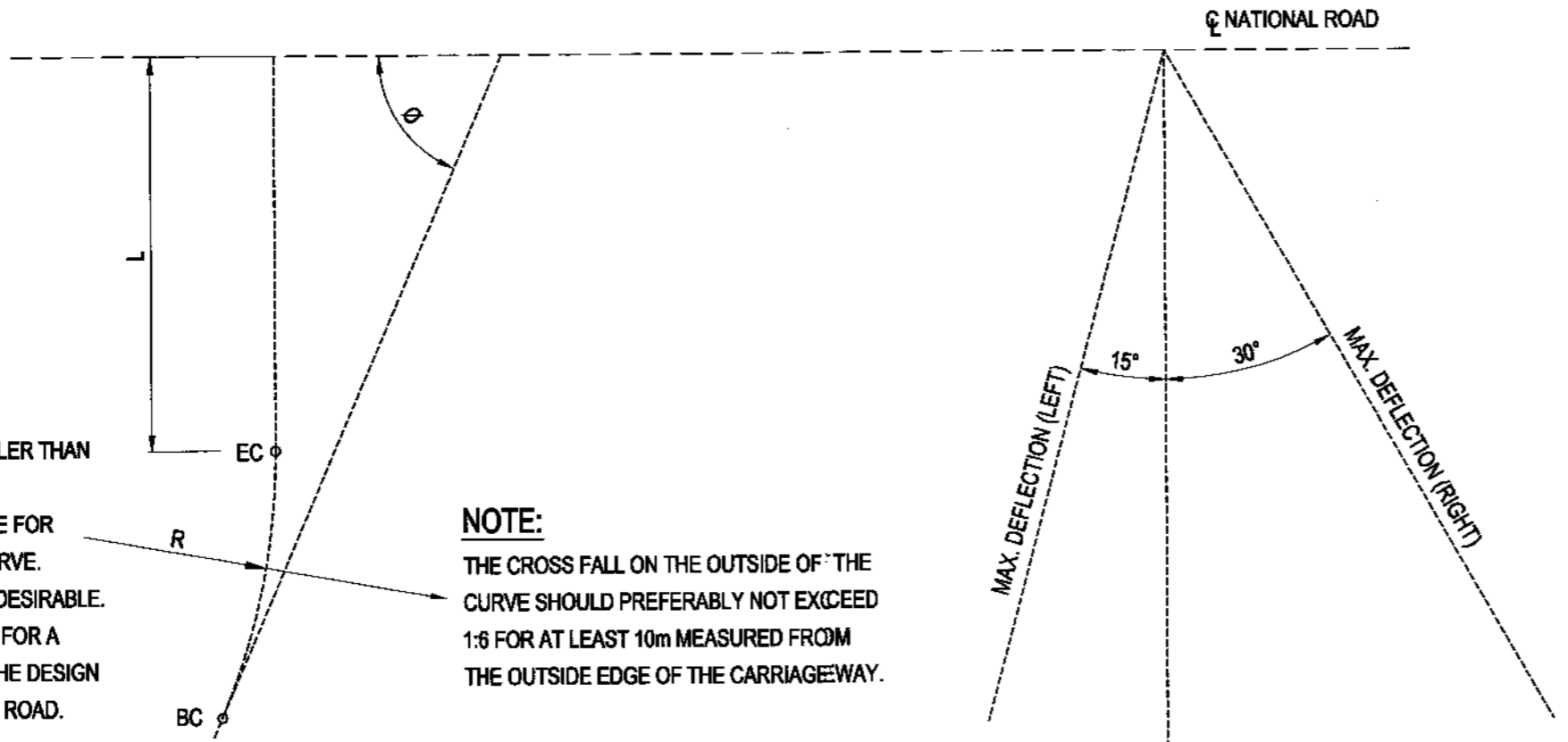

- NOTE**
1. θ = DEFLECTION ANGLE SMALLER THAN SAFE ANGLE.
 2. L = STOPPING SIGHT DISTANCE FOR DESIGN SPEED FOR LAST CURVE. MINIMUM LENGTH OF 155m IS DESIRABLE.
 3. R = CORRESPONDING RADIUS FOR A SPEED 15km/h LOWER THAN THE DESIGN SPEED FOR THE REST OF THE ROAD.

NOTE:
THE CROSS FALL ON THE OUTSIDE OF THE CURVE SHOULD PREFERABLY NOT EXCEED 1:6 FOR AT LEAST 10m MEASURED FROM THE OUTSIDE EDGE OF THE CARRIAGEWAY.

SAFE ANGLES AND STOPPING SIGHT DISTANCE AT T-JUNCTIONS
SCALE - N.T.S

- NOTE:**
1. GRADIENT ON BOTH ROADS SHOULD NOT EXCEED 3%, ESPECIALLY ON THE JUNCTION LEG.
 2. TABLE 1 CAN BE USED AS A BASIC GUIDELINE ON CONDITION THAT THE GRADIENTS ON BOTH THE JUNCTION AND PRIMARY ROADS DO NOT EXCEED 2%. THE SIGHT DISTANCE MUST BE MEASURED FROM AN EYE LEVEL OF 1,05m FROM A POINT 2m BEFORE THE STOP LINE ON THE JUNCTION ROAD TO AN OBJECT HEIGHT ON THE CENTRE LINE OF THE NATIONAL ROAD OF 1,30m.
 3. THE DESIRABLE MINIMUM SIGHT DISTANCE IS 300m.
 4. FOR DETAIL OF ROAD MARKINGS REFER TO THE SADC ROAD TRAFFIC SIGNS MANUAL.
 5. THIS PLAN SERVES AS A GUIDE LINE AND WELL MOTIVATED DEVIATIONS MAY BE CONSIDERED.
 6. WHERE APPLICABLE CROSS-SECTION DIMENSIONS MUST BE ADJUSTED ACCORDING TO THE APPROVED TYPICAL CROSS-SECTION BEING USED.

FOR LATEST VERSION CHECK www.nra.co.za

No.	DATE	VERSION / REVISION	APPROVED
V1	SEPT 2014	ORIGINAL VERSION	

SANRAL TYPICAL DRAWINGS

COPYRIGHT: THIS DRAWING IS PROTECTED IN TERMS OF THE COPYRIGHT ACT No. 98 OF 1978 AND MAY NOT BE REPRODUCED WITHOUT PERMISSION IN WRITING FROM SANRAL.

CONDITIONS FOR USE: CONSULTANTS APPOINTED BY SANRAL SHALL INCORPORATE THE TYPICAL DETAILS HEREON INTO THEIR SPECIFIC DESIGN FOR WHICH THEY WILL ASSUME FULL PROFESSIONAL RESPONSIBILITY. THIS TYPICAL DRAWING MAY NOT BE USED FOR TENDER PURPOSES.

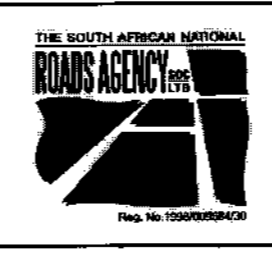

HEAD OFFICE
48 Tambolle Avenue
Val de Grace
Pretoria
0184
PO Box 415
Pretoria 0001
South Africa
Tel: (012) 844 8000

APPROVED
W. v. d. Merwe
DATE: 2015/06/26

TYPICAL DRAWINGS - ROADWORKS

T - JUNCTIONS & INTERSECTIONS

T - JUNCTION WITH GRAVEL

CLASS 2 ROADS

SANRAL DOC. No. (PDF)	1693224
SANRAL DOC. No. (DWG)	1797268
SANRAL DRAWING No.	TD-R-JI-1100-V1

APPENDIX C

ASSESSMENT METHODOLOGY

Assessment of Impacts

Direct, indirect and cumulative impacts associated with the projects must be assessed in terms of the following criteria:

- The **nature**, which shall include a description of what causes the effect, what will be affected and how it will be affected.
- The **extent**, wherein it will be indicated whether the impact will be local (limited to the immediate area or site of development) or regional, and a value between 1 and 5 will be assigned as appropriate (with 1 being low and 5 being high):
- The **duration**, wherein it will be indicated whether:
 - the lifetime of the impact will be of a very short duration (0–1 years) – assigned a score of 1;
 - the lifetime of the impact will be of a short duration (2-5 years) - assigned a score of 2;
 - medium-term (5–15 years) – assigned a score of 3;
 - long term (> 15 years) - assigned a score of 4; or
 - permanent - assigned a score of 5;
- The **magnitude**, quantified on a scale from 0-10, where 0 is small and will have no effect on the environment, 2 is minor and will not result in an impact on processes, 4 is low and will cause a slight impact on processes, 6 is moderate and will result in processes continuing but in a modified way, 8 is high (processes are altered to the extent that they temporarily cease), and 10 is very high and results in complete destruction of patterns and permanent cessation of processes.
- The **probability** of occurrence, which shall describe the likelihood of the impact actually occurring. Probability will be estimated on a scale of 1–5, where 1 is very improbable (probably will not happen), 2 is improbable (some possibility, but low likelihood), 3 is probable (distinct possibility), 4 is highly probable (most likely) and 5 is definite (impact will occur regardless of any prevention measures).
- The **significance**, which shall be determined through a synthesis of the characteristics described above and can be assessed as low, medium or high; and
- the status, which will be described as either positive, negative or neutral.
- the degree to which the impact can be reversed.
- the degree to which the impact may cause irreplaceable loss of resources.
- the degree to which the impact can be mitigated.

The significance is calculated by combining the criteria in the following formula:

$$S=(E+D+M)P$$

S = Significance weighting

E = Extent

D = Duration

M = Magnitude

P = Probability

The **significance weightings** for each potential impact are as follows:

- < 30 points: Low (i.e. where this impact would not have a direct influence on the decision to develop in the area),
- 30-60 points: Medium (i.e. where the impact could influence the decision to develop in the area unless it is effectively mitigated),
- > 60 points: High (i.e. where the impact must have an influence on the decision process to develop in the area).

Assessment of Cumulative Impacts

As per DEA's requirements, specialists are required to assess the cumulative impacts. In this regard, please refer to the methodology below that will need to be used for the assessment of Cumulative Impacts.

"Cumulative Impact", in relation to an activity, means the past, current and reasonably foreseeable future impact of an activity, considered together with the impact of activities associated with that activity, that in itself may not be significant, but may become significant when added to existing and reasonably foreseeable impacts eventuating from similar or diverse activities .

The role of the cumulative assessment is to test if such impacts are relevant to the proposed project in the proposed location (i.e. whether the addition of the proposed project in the area will increase the impact). This section should address whether the construction of the proposed development will result in:

- Unacceptable risk
- Unacceptable loss
- Complete or whole-scale changes to the environment or sense of place
- Unacceptable increase in impact

The specialist is required to conclude if the proposed development will result in any unacceptable loss or impact considering all the projects proposed in the area.